



®

Innovative Technology

INTELLIGENCE IN VALIDATION



A.u.S. SPIELGERÄTE GMBH

SCHEYDGASSE 48, AT 1210 WIEN

+43 (0) 1 271 66 00 65 FAX +43 (0) 1 271 66 00 75

www.aus.at verkauf@aus.at

NV200 Spectral

[GA02119]



USER MANUAL

User Manual – NV200 Spectral

[<< Back to Contents](#)

Document Name:	User Manual – NV200 Spectral
Document Version:	1.0
Date of Release:	27/04/2018

TABLE OF CONTENTS

1	DOCUMENT INTRODUCTION	4
1.1	RELATED DOCUMENTS	4
1.2	MANUAL AMENDMENTS.....	4
1.3	COPYRIGHT	4
1.4	LIMITED WARRANTY	4
1.5	PRODUCT SAFETY INFORMATION	5
1.6	DISCLAIMER	5
2	PRODUCT INTRODUCTION	8
2.1	GENERAL DESCRIPTION.....	8
2.2	KEY FEATURES	8
2.3	TYPICAL APPLICATIONS	8
2.4	COMPONENT OVERVIEW	8
2.4.1	<i>Bezel Options</i>	10
2.4.2	<i>Cashbox Options</i>	10
2.4.3	<i>Module Options</i>	10
2.4.4	<i>Consumables</i>	10
3	TECHNICAL DATA	11
3.1	DIMENSIONS	11
3.2	WEIGHT	11
3.2.1	<i>Standard Unit – No Cashbox</i>	11
3.2.2	<i>Cashbox Options</i>	11
3.2.3	<i>Module Options</i>	12
3.3	ENVIRONMENTAL REQUIREMENTS	12
3.4	POWER REQUIREMENTS	12
3.4.1	<i>Supply Voltages</i>	12
3.4.2	<i>Supply Currents</i>	12
3.4.3	<i>Power Supply Guidance</i>	13
3.5	INTERFACE LOGIC LEVELS	13
3.5.1	<i>Opto-Isolated Inputs</i>	13
3.6	RELIABILITY DATA.....	13
3.7	MEDIA REQUIREMENTS	14
4	MECHANICAL INSTALLATION	15
4.1	COMPATIBILITY	15
4.1.1	<i>Hardware Compatibility</i>	15
4.1.1.1	Machine Mounting	15
4.1.1.2	Machine Interfacing.....	15
4.1.1.3	Power Supply	15
4.1.2	<i>Software Compatibility</i>	16
4.1.2.1	Interface Protocols.....	16
4.1.2.2	Re-programming	16
4.2	BEZEL MOUNTING.....	17
4.2.1	<i>Bezel Fitting</i>	17
4.3	CASHBOX REMOVAL & OPENING.....	19
4.4	TEBS CASH BAG REMOVAL & REPLACEMENT	21
4.5	LOCK MOUNTING.....	22
4.5.1	<i>Lock Fitting</i>	22



User Manual – NV200 Spectral

[<< Back to Contents](#)

4.5.2	Lock fitting – Standard Cashbox	25
4.5.3	Lock Fitting - TEBS Cashbox	26
4.5.4	Lock Specifications	26
4.5.5	Lock Cam.....	26
4.6	DOCKING PLATE MOUNTING	27
4.7	LOADING PAPER INTO THE SMART TICKET	29
4.7.1	Roll	29
4.7.1.1	Top.....	29
4.8	MACHINE MOUNTING.....	29
4.8.1	Machine Mounting – Standard Cashbox.....	29
4.8.2	Machine Mounting – TEBS.....	30
4.8.3	Earth Bonding	30
4.8.4	Screw Specifications.....	31
4.8.5	Things to consider.....	31
5	SOFTWARE INSTALLATION AND CONFIGURATION.....	32
5.1	INTRODUCTION	32
5.2	SOFTWARE DOWNLOADS	32
5.3	DRIVERS	32
5.4	DATASET/FIRMWARE PROGRAMMING	32
5.4.1	Validator Manager.....	32
5.4.1.1	General Description	32
5.4.1.2	System Requirements	32
5.4.1.3	Hardware Setup	33
5.4.1.4	Switching to Programming Mode (SSP)	33
5.4.1.5	Programming the device.....	33
5.4.2	SD Card	34
5.4.2.1	General Description	34
5.4.2.2	Hardware Requirements.....	34
5.4.2.3	Re-programming via SD Card	35
5.4.3	Remote Updates	35
5.4.3.1	General Description	35
6	PROTOCOLS AND INTERFACING.....	36
6.1	INTRODUCTION	36
6.2	INTERFACE CONNECTORS	36
6.3	USER INTERFACES.....	37
6.3.1.1	Dip Switches on the NV200 Spectral.....	37
6.3.1.2	Dip Switches on the Payout module	37
6.3.1.3	Smart Ticket Button	38
6.3.1.4	Smart Ticket Dip Switches.....	38
6.4	SSP AND E SSP	40
6.4.1	General Description	40
6.4.2	Pin Assignments	40
6.4.3	Setup Examples.....	41
6.4.3.1	NV200 Spectral	41
6.4.3.2	NV200 Spectral and Smart Coin System	42
6.5	ccTALK®	43
6.5.1	General Description	43
6.5.2	Pin Assignments.....	43
6.5.3	ccTalk® DES Encryption.....	44
6.5.4	Setup Example Drawings	44
6.5.4.1	NV200 Spectral	44
6.5.4.2	NV200 Spectral with Payout Module (SPO)	44
7	ROUTINE MAINTENANCE.....	45
7.1	INTRODUCTION	45
7.2	RECOMMENDED CLEANING INTERVALS	45
7.3	CLEANING THE NV200 SPECTRAL.....	45
7.3.1	Cleaning the Validator.....	45



User Manual – NV200 Spectral

[<< Back to Contents](#)

7.3.2	Cleaning the TEBS Cashbox.....	46
7.3.3	Cleaning the Ticket Module	48
8	FIRST LEVEL SUPPORT	52
8.1	BEZEL/STATUS LED FLASH CODES	52
8.2	NV200 SPECTRAL MODULE FLASH CODES.....	54
8.2.1	TEBS Lock Flash Codes.....	54
8.2.2	Payout Module Flash Codes.....	54
8.2.3	Ticket Module Flash Codes.....	55
8.3	CHECKING POWER CONNECTIONS TO THE UNIT	55
8.3.1	NV200 Spectral Connections.....	56
8.3.2	TEBS Connections:.....	56
8.3.3	Smart Payout Connection:	57
8.3.4	Smart Ticket Connection:	57
8.3.5	Checking the Supply Voltage.....	57
8.4	COMMUNICATION WITH THE HOST	57
9	SECOND LEVEL SUPPORT	59
9.1	OBTAINING LOGS USING SD CARD	59
9.2	CLEARING A JAM FROM THE NV200 SPECTRAL	59
9.2.1	Note is in the note path	59
9.2.2	Note is visible once the NV200 Spectral has been removed	59
9.2.3	Note isn't visible once the NV200 Spectral has been removed	60
9.3	CLEARING A JAM FROM THE TEBS CASHBOX	61
9.4	CLEARING A JAM FROM THE PAYOUT MODULE.....	62
9.5	DIVERTER AND TAPE POSITIONS IN THE PAYOUT MODULE	65
9.6	CLEARING A JAM FROM THE TICKET MODULE.....	65
9.7	TESTING AFTER AN ERROR HAS BEEN CLEARED	65
10	COMPLIANCES AND APPROVALS	66
10.1	EC DECLARATION OF CONFORMITY	66
10.2	FCC APPROVAL.....	66
10.3	CENTRAL BANK APPROVALS.....	66
11	APPENDIX	67
11.1	CABLE DRAWINGS	67
11.1.1	CN00214.....	67
11.1.2	CN00292.....	68
11.1.3	CN00414.....	69
11.1.4	CN00487.....	70
11.2	LOCK SPECIFICATION	71
11.2.1	Keyless Locking Cam.....	72
11.2.2	TEBS Locking Cam	73
11.3	CONNECTOR SPECIFICATIONS	74
11.4	SWITCHING TO PROGRAMMING MODE (SSP)	74
11.5	FREE FALL CASHBOX ADVICE.....	74
11.6	cCTALK DES ENCRYPTION – TRUSTED MODE.....	74
11.7	ESCROW	74
11.8	ESCROW CONTROL	75
11.9	FILE NAMING CONVENTION.....	76



1 DOCUMENT INTRODUCTION

1.1 Related Documents

This document should be read together with the following:

For SSP/eSSP:

[Protocol Manual – SSP \(GA138\): SSP Interface Protocol Specification for integration](#)

[SSP Implementation Guide \(GA973\): Information for programmers and integrators](#)

For CCTalk:

[ITL BNV CCTalk Specification \(GA966\): CCTalk Integration Guide](#)

[CC2 Manual \(GA863\): CC2 Interface Protocol Specification for Integration](#)

For Software:

[Software Manual \(GA2037\) – ITL Software Guide](#)

For other third-party interface protocols contact support@innovative-technology.co.uk

1.2 Manual Amendments

Rev.	Date	Amendment Details	Issued by
1.0	27/04/2018	First Issue	CW

1.3 Copyright

This manual set is Copyright © Innovative Technology Ltd. 2018. No part of this publication may be reproduced in any form or by any means used to make any derivative such as translation, transformation, or adaptation without permission from Innovative Technology Ltd. The contents of this manual set may be subject to change without prior notice.

1.4 Limited Warranty

Innovative Technology Ltd warrants each of its hardware products to be free from defects in workmanship and materials under normal use and service for a period commencing on the date of purchase from Innovative Technology Ltd or its Authorized Reseller, and extending for the length of time stipulated by Innovative Technology Ltd.

A list of Innovative Technology Ltd offices can be found in every section of this manual set. If the product proves defective within the applicable warranty period, Innovative Technology Ltd will repair or replace the product. Innovative Technology Ltd shall have the sole discretion whether to repair or replace, and any replacement product supplied may be new or reconditioned.



[<< Back to Contents](#)

The foregoing warranties and remedies are exclusive and are in lieu of all other warranties, expressed or implied, either in fact or by operation of law, statutory or otherwise, including warranties of merchantability and fitness for a particular purpose.

Innovative Technology Ltd shall not be liable under this warranty if it's testing and examination disclose that the alleged defect in the product does not exist or was caused by the customer's or any third person's misuse, neglect, improper installation or testing, unauthorized attempts to repair, or any other cause beyond the range of the intended use. In no event will Innovative Technology Ltd be liable for any damages, including loss of profits, cost of cover or other incidental, consequential or indirect damages arising out the installation, maintenance, use, performance, failure or interruption of an Innovative Technology Ltd product, however caused.

1.5 Product Safety Information

Throughout this user manual, we may draw your attention to key safety points that you should be aware of when using or maintaining the product.

These safety points will be highlighted in a box, like this:

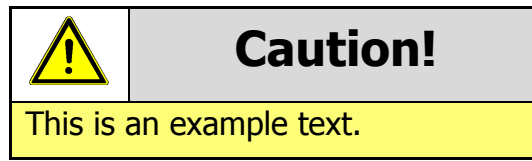

This user manual and the information it contains is only applicable to the model stated on the front cover and must not be used with any other make or model.

1.6 Disclaimer

Innovative Technology Ltd is not responsible for any loss, harm, or damage caused by the installation and use of this product. This does not affect your local statutory rights. If in doubt contact Innovative Technology for details of any changes.

Innovative Technology Ltd has a policy of continual product improvement. As a result, the products supplied may vary from the specification described here.

Innovative Technology Ltd does not accept liability for any errors or omissions contained within this document. Innovative Technology Ltd shall not incur any penalties arising out of the adherence to, interpretation of, or reliance on, this standard.





Safety Notice! Read before using this product!

Safety Notice - Warning. Ensure power is removed before allowing access to the inside of this product. Ensure any static build up is discharged before allowing access to any part of this product or media contained. Always earth this product/base plate in accordance with the manual.

For use only in or with complete equipment where the acceptability of the combination is determined by UL LLC. When installed in an end-product, consideration must be given to the following:

- The power supply terminals and/or connectors are: Not investigated for field wiring
- The investigated Pollution Degree is: 2
- The following end-product enclosures are required: Mechanical, Fire
- Equipment not investigated for accessibility to children – to be evaluated in end-user application

Sicherheitshinweis – Warnung: Es muss sichergestellt werden, dass das Gerät von der Versorgungsspannung getrennt wird, bevor ein Eingriff in das Innere des Gerätes erfolgt. Es muss sichergestellt werden, dass jegliche statische Aufladung des Gerätes entladen wird, bevor auf das Gerät oder auf innerhalb des Gerätes befindliche Objekte zugegriffen wird. Die Erdung des Gerätes muss immer gemäß Handbuch erfolgen.

Nur für die Verwendung in oder mit kompletter Ausstattung, dessen Eignung und Kombination von der UL LLC ermittelt wurde. Bei der Installation in einem Endprodukt, muss folgendes berücksichtigt werden:

- Die Spannungsversorgungsklemmen und/oder Verbinder sind: Feldverkabelung wurde nicht untersucht
- Der untersuchte Verschmutzungsgrad ist: 2
- Folgende Anforderungen an die Gehäuse des Endproduktes sind gefordert: Mechanisch, Feuer

Aviso de seguridad: Asegúrese de que la alimentación está desconectada y de que toda la energía estática es descargada antes de manipular este producto. Conecte a tierra la chapa base de la manera que se indica en el manual.

Solo para uso con dispositivos con los cuales la compatibilidad ha sido certificada por UL LLC. Tras su instalación en producto acabado, tener en cuenta lo siguiente:

- Los conectores y terminales de alimentación son: No se ha investigado/especificado cableado externo.
- El grado de contaminación determinado es: 2
- Los siguientes manuales/certificados de producto final son requeridos: Mecánico, Fuego

Avis de sécurité : Assurez-vous que l'alimentation est coupée et que toute l'énergie statique est déchargé avant de manipuler ce produit. Connecter à la terre, la plaque de base à la manière indiquée dans le manuel.

A utiliser Seulement avec les dispositifs dont la compatibilité a été certifiée par UL LLC. Après son installation dans le produit fini, prendre en considération ce qui suit:-

- Les connecteurs et les bornes d'alimentation sont : cela n'a pas été étudié/spécifié câblage externe.
- Le degré de contamination déterminé est : 2
- Les manuels suivants / les certificats du produit final sont nécessaires : mécanique, incendie



Bezpečnostní upozornění. Před manipulací uvnitř tohoto produktu se ujistěte, že je produkt odpojen od zdroje elektrického napětí. Ujistěte se, že jakýkoliv elektrostatický náboj byl vybit před manipulací s jakoukoliv částí tohoto produktu nebo obsaženým médiem. Vždy uzemněte tento produkt/základovou desku v souladu s návodem.

Pouze pro použití v nebo s kompletním vybavením, kde je přijatelnost kombinace určena UL LLC. Při instalaci v konečném produktu je třeba zvážit následující:

- Napájecí svorky a/nebo konektory: Nejsou sledované pro externí kabeláž
- Sledovaný stupeň znečištění je: 2
- Následující krytí konečného produktu jsou požadované: Mechanické, Protipožární



[<< Back to Contents](#)

	<h2>Caution! – IR and UV Radiation</h2>	
	 	<ul style="list-style-type: none">• Possible skin or eye damage due to presence of IR and UV radiation internally• Disconnect power before servicing.• Employ appropriate PPE measures• Follow safety precautions given in IEC 62471



2 PRODUCT INTRODUCTION

2.1 General Description

The NV200 Spectral is a highly secure and technologically advanced banknote validator. State of the art spectral sensors offer complete note image capture by scanning over 4.8 million data points to authenticate the validity of notes. The unit boasts 99%+ first time acceptance of new and street grade notes with a note to note processing time of 2 seconds.

The unit contains a number of security features including optical and mechanical anti-strimming technology that delivers outstanding fraud protection. The NV200 Spectral's cutting-edge note centring mechanism, together with 4-way barcode acceptance bring the user exceptional note handling and increased ticket acceptance rates.

2.2 Key Features

- 100% note image capture - 4.8 million data points
- 99%+ first time acceptance of new & street grade notes
- Stained note detection
- 2 second note to note processing
- Modular design - recycler or ticket printer available

2.3 Typical Applications

The NV200 Spectral validator can be used in a variety of situations where high security and high-volume bank note acceptance and validation are needed. Some typical applications are:

- AWP and SWP applications
- Self-Serve and Retail
- Kiosks
- Casinos
- Parking and Ticketing
- Vending
- Retail environment.
- POS Systems



2.4 Component Overview



Cashbox options



Lockable,
Removable 500
note cashbox



Lockable,
Removable 1000
note cashbox



TEBS – Tamper
Evident Bagging
System



Payout Module –
True Multi-Note
recycling

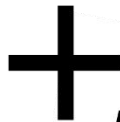

Ticket Module –
TITO Solution



[<< Back to Contents](#)

2.4.1 Bezel Options

ITL Part Number	Description
PA00610	Standard Bezel (85mm)
PA00639	Metal Bezel
PA01038	Self-Aligning Bezel (White)
PA02053	Self-Aligning Bezel (Black)

2.4.2 Cashbox Options

ITL Part Number	Description
PA02738	500 Note Cashbox and Chassis
PA02930	1000 Note Cashbox and Chassis
PA02198	TEBS – Tamper Evident Bag System

2.4.3 Module Options

ITL Part Number	Description
PA02783	Payout Module
PA1062	Roll Top Ticket Module

2.4.4 Consumables

ITL Part Number	Description
PA02196	TEBS Safe Bag (Box of 140 Bags)
LB02012	Roll Tickets (Box of 12 Rolls)



3 TECHNICAL DATA

3.1 Dimensions

The dimensions below are for the NV200 Spectral with 500 note cashbox. Other cashbox / module options will change the dimensions. For dimensional drawings of other configurations contact support@innovative-technology.co.uk

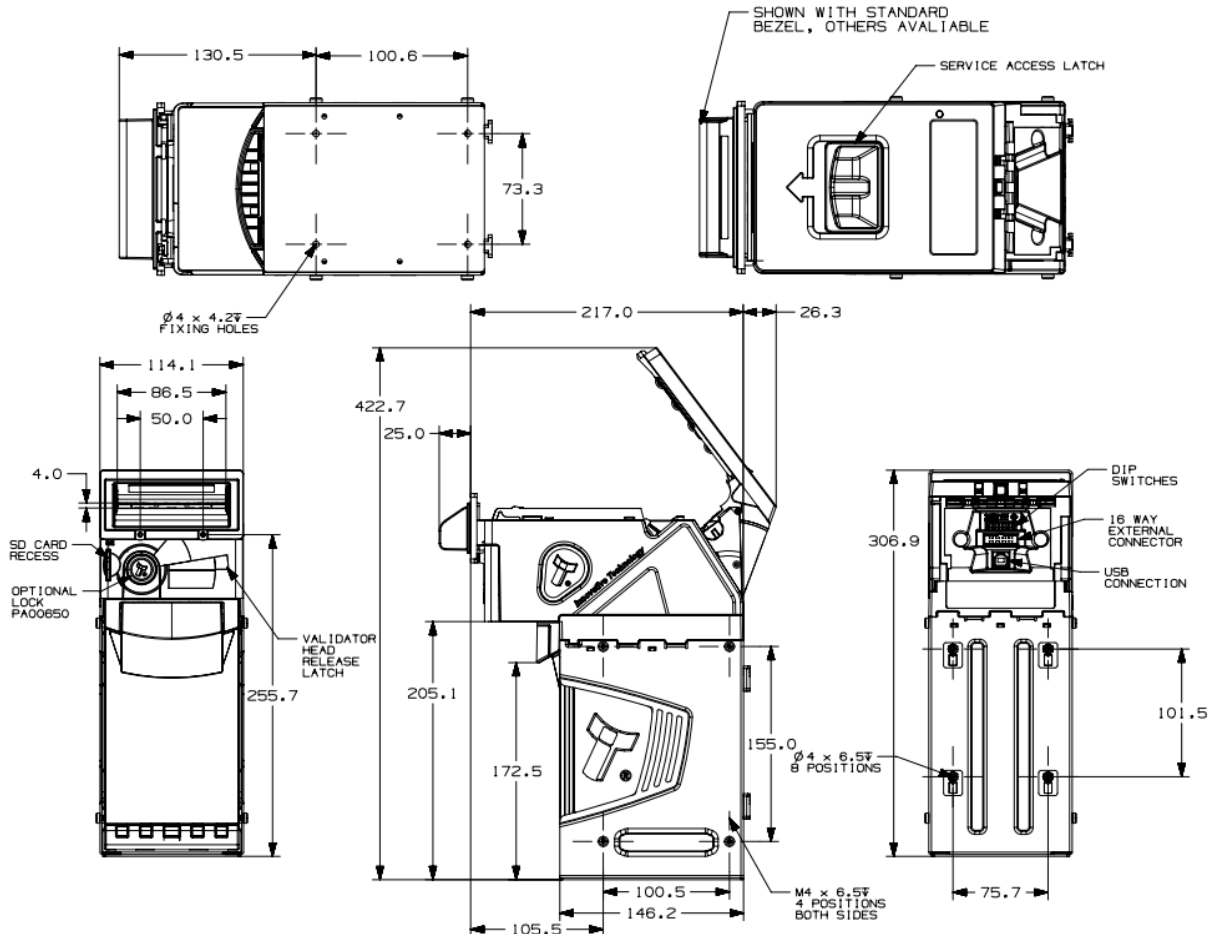

3.2 Weight

The tables below show the weights for the individual components of the product.

For example, and NV200 Spectral with Standard Bezel and 500 Note Cashbox with Chassis would weigh 3.21Kg (1.20 Kg + 2.01 Kg)

3.2.1 Standard Unit – No Cashbox

Unit	Weight Empty	Weight Full
NV200 Spectral – Standard Bezel	1.20 Kg	N/A

3.2.2 Cashbox Options

Unit	Weight Empty	Weight Full
500 Note Cashbox with Chassis	2.01 Kg	2.46 Kg
1000 Note Cashbox with Chassis	2.19 Kg	3.09 Kg
TEBS Cashbox (Tamper Evident Bag System)	6.95 Kg	7.75 Kg



[<< Back to Contents](#)

3.2.3 Module Options

Unit	Weight Empty	Weight Full
Payout Module	2.54 Kg	2.60 Kg
Ticket Module	1.34 Kg	2.64 Kg

3.3 Environmental Requirements

Environment	Minimum	Maximum
Temperature	+3°C	+50°C
Humidity	5%	95% Non-condensing

3.4 Power Requirements

3.4.1 Supply Voltages

Supply Voltage	Minimum	Nominal	Maximum
Supply Voltage (V DC)	+ 11.8 V DC / +22.6vDC	+ 12 V DC / +24vDC	+ 14.2 V DC / +26.4vDC
Supply Ripple Voltage	0 V	0 V	0.25 V @ 100 Hz

The TEBS cashbox and Ticket module require the unit is run at 24v (±10%).

3.4.2 Supply Currents

The supply current required to run the NV200 Spectral will vary during the phases of operation. Below is a table detailing the required current information

Phase of Operation	Minimum
Standby	350mA (using 12v PSU) 200mA (using 24v PSU)
Running	1.5A
Peak	3.5A

To use the extra modules such as the payout or ticket module additional power is required. The table below explains the additional current draw required.

Phase of operation	Additional Current Draw TEBS (A)	Additional Current Draw Payout (A)	Additional Current Draw Ticket (A)
Standby	200mA	-	-
Running	-	1.5A	1A
Peak	2.6A	2A	5A*

*Maximum current required to print a solid black ticket

For an NV200 Spectral with a TEBS cashbox and payout module, the peak current draw would be:

$$3.5A + 2.6A + 2A = 8.1A$$



[<< Back to Contents](#)

3.4.3 Power Supply Guidance

Check the power requirements of the host machine and other peripherals to dimension a suitable power environment for the machine setup.

The unit shall be supplied from a source specified as Electrical Energy Source Class 1 (ES1) to IEC/UL 62368-1, or specified as SELV according to IEC/UL 60950-1

TDK Lambda manufactures suitable power supplies. See table below for further details.

Power Supply Unit	Specification	RS Stock Code	Farnell Stock Code	Suitable for use with
TDK Lambda RWS-50B-12	+12 V DC / 4.3 A	839-9626	2452725	NV200 Spectral Standalone
TDK Lambda RWS-150B-24	+24 V DC / 6.3 A	813-9103	2444003	NV200 Spectral with TEBS or Payout Module
TDK Lambda RWS-300B-24	+24 V DC / 12.5A	813-9128	2419997	NV200 Spectral with TEBS and Payout/Ticket Module

3.5 Interface Logic Levels

Interface Logic Levels	Logic Low	Logic High
Inputs	0V to +0.5V	+3.7V to +12V
Outputs with 2K2Ω pull-up resistor	+0.6V	Pull-up voltage of host interface
Maximum Current Sink	50mA per Output	

3.5.1 Opto-Isolated Inputs

The NV200 Spectral natively supports Opto-isolated communication, the connection requires a reciprocal circuit to be established on the host side. The pin outs for the opto-isolated inputs can be found in [Section 6.4.2](#).

3.6 Reliability Data

Below is an explanation outlining the Mean Cycles Between Failure (MCBF) & Mean Cycles Between Interruption (MCBI) for the NV200 Spectral. Where a cycle is defined as a note/ticket either stacked, stored or paid-out. An example is if £20 is accepted and a £10 paid out that would be classed as 2 cycles.

The difference between MCBF and MCBI is that a failure is classed as an event which will require a service call – e.g. unit is seeing poor acceptance. Whereas an interruption is an event which store/site staff could rectify without a trained engineer present – e.g. clearing a note path jam.

As shown in [Section 2.4](#) the NV200 Spectral is a modular solution and these modules increase the complexity of the system. As such, each time one of these additional modules are attached the current MCBF and MCBI is halved. The MCBF for the NV200 Spectral is 200,000 cycles.



3.7 Media Requirements

The NV200 Spectral is capable of handling multiple denominations simultaneously, the media that can be accepted includes but is not limited to: -

- Paper notes
- Polymer notes
- Windowed notes
- Barcoded tickets

The minimum and maximum dimension for media IN is as follows:

	Minimum	Maximum
Length	110mm	170mm
Width	56mm	85mm

When using the optional smart payout module, the media dimensions for notes routed to the payout are as follows:

	Minimum	Maximum
Length	110mm	170mm
Width	56mm	82mm

When using the optional smart ticket module, the paper requirements are as follows:

Roll	Minimum	Maximum
Length	N/A	N/A
Width	80mm	80mm

General	Minimum	Maximum
Thickness	100µm	120µm
Perforation Strength	0.7kg	1.3kg



4 MECHANICAL INSTALLATION

4.1 Compatibility

4.1.1 Hardware Compatibility

4.1.1.1 Machine Mounting

Assuming the suitable bezel (and cashbox) type has been ordered the NV200 Spectral can be used as fitting replacement for the following ITL products only:

- NV200

Innovative Technology Ltd. has a policy of continuous product improvement. Due to design changes older model or product bezels (and cashboxes) may not be compatible with the NV200 Spectral. Specifically, the NV200 Spectral head is not backwards compatible with the NV200 cashbox and chassis.

However, new product deliveries always include a bezel (and cashbox) that must be used.

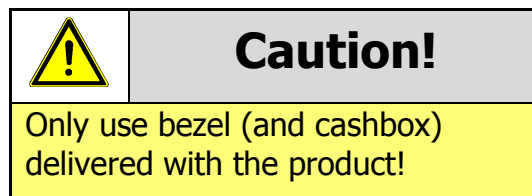

4.1.1.2 Machine Interfacing

By design the NV200 Spectral is pin to pin compatible with the suitable fitting replacement products listed in [Section 4.1.1.1](#). No changes to existing machine harnessing are required.

4.1.1.3 Power Supply

It is vital that the NV200 Spectral is connected to a power supply able to provide the required power environment. A weak power supply causes malfunctioning of the NV200 Spectral such as note rejects or missing credits. If the NV200 Spectral is used as a fitting replacement for an older model or product we recommend checking the power supply specifications of the machine. The power supply of the machine might be designed for the older model or product but not suitable for the NV200 Spectral. The NV200 Spectral might have higher power consumption. Refer to [Section 3.4](#) for full power requirement details of the NV200 Spectral.

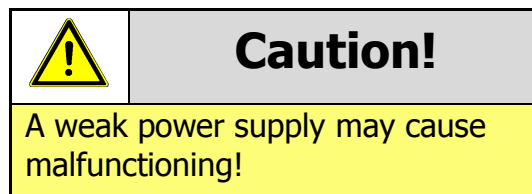

[<< Back to Contents](#)

4.1.2 Software Compatibility

4.1.2.1 Interface Protocols

When using the NV200 Spectral as a fitting replacement for an older model or product some events such as credits may be given incorrectly. This is due to improved firmware routines and faster motors being used. This may cause missing events such as credits in those host machines where timeouts are defined for the older model or product. Contact the machine manufacturer for full compatibility of the NV200 Spectral.

	Caution!
Timing issues may cause missing events such as credits!	

4.1.2.2 Re-programming

For re-programming the NV200 Spectral always use the latest version of Validator Manager available for download on our website. Older versions may not support the NV200 Spectral. For further details on Re-programming the NV200 Spectral refer to [Section 5.4](#).

	Caution!
Older versions of Validator Manager may not support the NV200 Spectral!	



[<< Back to Contents](#)

4.2 Bezel Mounting

4.2.1 Bezel Fitting

1. Open Note Path

Pull the top latch in the direction shown to unlock the note path



2. Open Upper Note Path

When the note path has unlocked, lift the upper part to give clear access to the front.



3. Attach Bezel Cable

Plug the bezel cable into the connection socket on the front.



Ensure red wire is visible in the top right corner of the connector



[<< Back to Contents](#)

4. Insert Bezel

Slide the bezel down into the slots on the front of the bezel

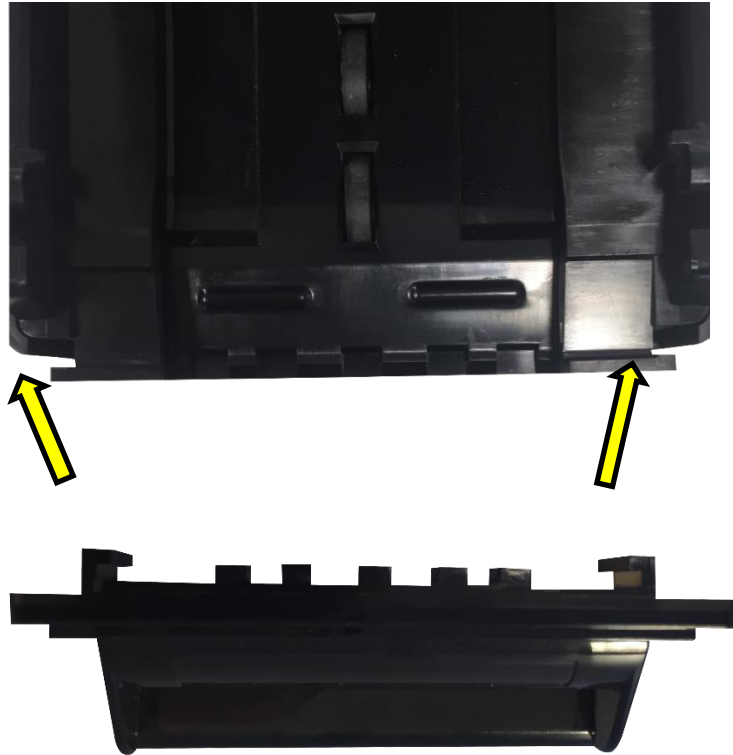

5. Close Note Path

Push the upper note path back down until you hear it click firmly back into place



4.3 Cashbox Removal & Opening

1. NV200 Spectral

The image to the right shows the NV200 Spectral with 500 note cashbox.



2. Cashbox Handle

Pull the cashbox handle forward, this will unlatch the cashbox, allowing it to be slid forward from the chassis.



[<< Back to Contents](#)

3. Slide Cashbox Forward

Continue to pull the handle forward, sliding the cashbox completely free from the chassis



4. Turn Cashbox Over

To access the cash, turn the cashbox as the door is on the bottom.



5. Open Cashbox

Push the black door latch in and lift the door at the same time.



[<< Back to Contents](#)

4.4 TEBS Cash Bag Removal & Replacement

Unlike the traditional cashbox, the TEBS has both a software and hardware lock. Before the cashbox can be removed the software, lock must have been enabled (when enabled the lock is green).

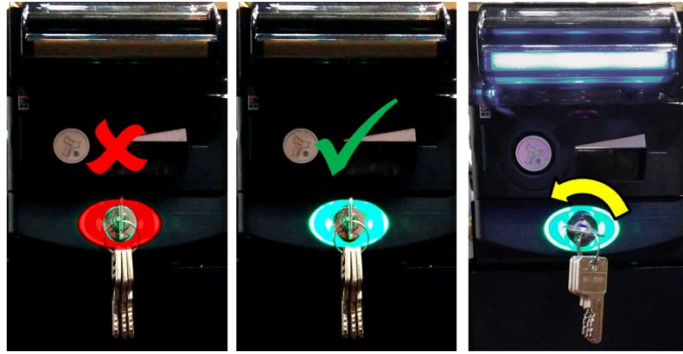

Once the key has been turned the bezel will begin to flash the cashbox can be removed as shown on the right.



To remove the cashbag, slide the catch to the side and lift the cash bag out of the cashbox. As shown to the right.

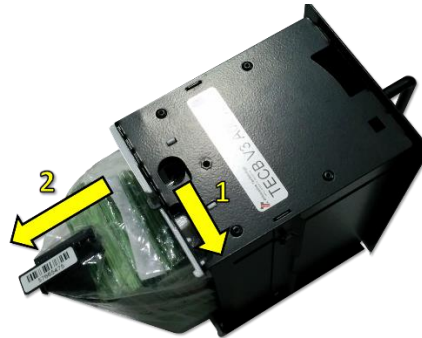

To fit the cash bag insert the bottom lug, slide the latch to the slide and push the bag into place. Ensuring the barcode is sat in place.



Slide the cash bag back into the TEBS and turn the lock – the lock will go red. The stacker will audibly cycle and the bezel flash code will disable showing the barcode has been read.

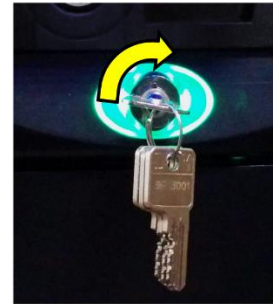

4.5 Lock Mounting

4.5.1 Lock Fitting

1. Lock Location

The Lock can be fitted to the front of the NV200 Spectral replacing the red front insert (shown to the right) which ships by default



2. Remove head from chassis

Before the lock can be installed, remove the NV200 Spectral from the cashbox chassis. Lift the latch, slide the head forward and lift the head away from the chassis.



[<< Back to Contents](#)

3. Remove red insert

There are 2xT8 screws located on the underside of the NV200 Spectral, remove those and lift away the plastic insert.

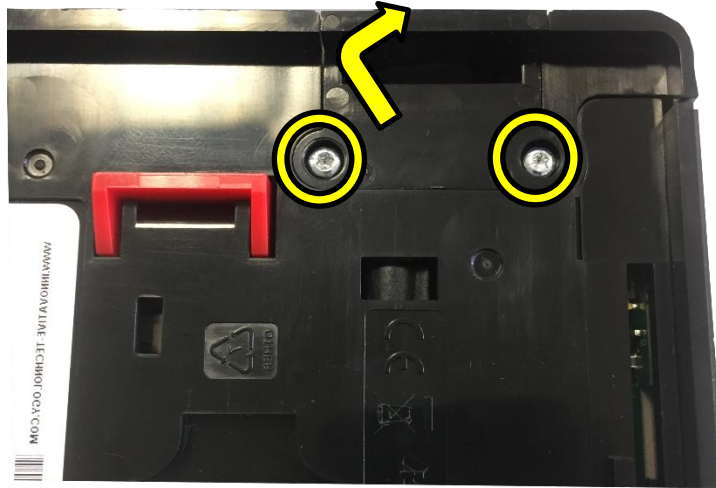

4. Remove Locking Cam

Press the plastic clip together and remove the locking cam.



5. Remove Plastic Insert

To remove the plastic insert, from the lock mount, press the two clips on the side together and push through. Insert the cam lock in its place.



[<< Back to Contents](#)

6. Re-attach Locking Cam

Re-attach the locking cam onto the barrel of the lock and tighten.



7. Fit Assembled Lock

To fit the assembled lock into the unit, place the bottom in first then push the top into position.

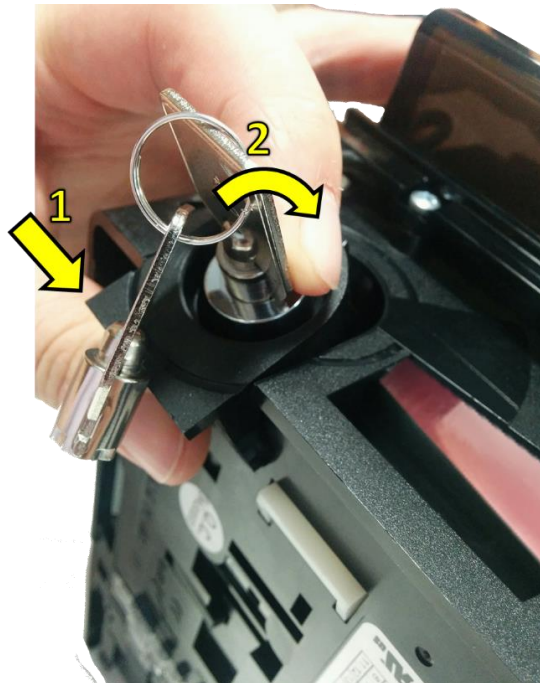

8. Screw in place

Turn the unit upside down and screw in the 2xT8 screws previously removed.

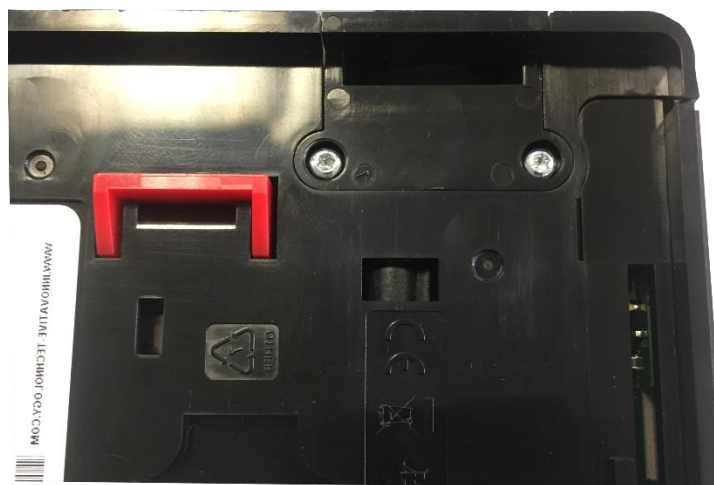

4.5.2 Lock fitting – Standard Cashbox

1. Cashbox Lock Location

The standard NV200 Spectral cashbox can be fitted with 2 locks for security. These are located on the bottom of the cashbox on the hinged door.



2. Remove Blanking Plates and Fit Lock

Similarly, to fitting a lock on the front of the NV200 Spectral remove the locking cam and blanking plate which is there by default and replace with the desired lock.

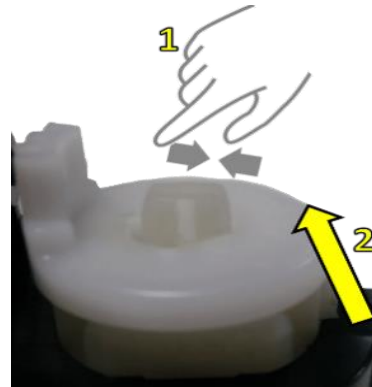

3. Finish Installation

With the lock in place add the washer and the locking cam.

Ensure when the keylock is turned the locking cam is inserted in the same position it was previously removed otherwise it can cause interference.

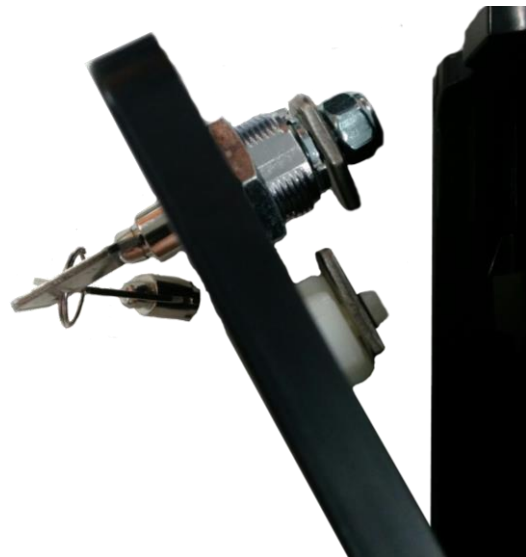

[<< Back to Contents](#)

4.5.3 Lock Fitting - TEBS Cashbox

The TEBS comes installed with a lock from the factory. The standard lock fitting for the TEBS cashbox is PA02540.

4.5.4 Lock Specifications

Locks for the NV200 Spectral are available from Innovative Technology Ltd.

ITL Part Number: PA00650

Webshop Link: <http://innovative-technology.com/shop/NV200-spares/lock-detail>

There is also a keyless lock assembly available, this comes as standard on the 1000 note cashbox.

ITL Part Number: PA02713

There are various lock manufacturers and distributors. Refer to [Appendix 11.2](#) for lock specification.

4.5.5 Lock Cam

The following Lock Cam needs to be ordered from Innovative Technology Ltd. additionally to the lock for full locking capability.

NV200 Spectral Lock Cam Part Number: PM00614

Webshop Link: <http://innovative-technology.com/shop/NV200-spares/NV200-latch-and-base-assembly-detail>

Cashbox Lock Cam Part Number: MC00247

Webshop Link: <http://innovative-technology.com/shop/NV200-spares/NV200-cashbox-lock-cam-detail>



[<< Back to Contents](#)

4.6 Docking Plate Mounting

When using the docking plate, you will need a different cable to connect the NV200 Spectral to the power supply, as the connector is different.

1. Slide NV200 Spectral Forward

Lift the latch on the front of the NV200 Spectral head and slide it forward on the chassis



[<< Back to Contents](#)

2. Attach the docking plate

Align the holes in the docking plate with the mounting points on the back of the NV200 Spectral chassis

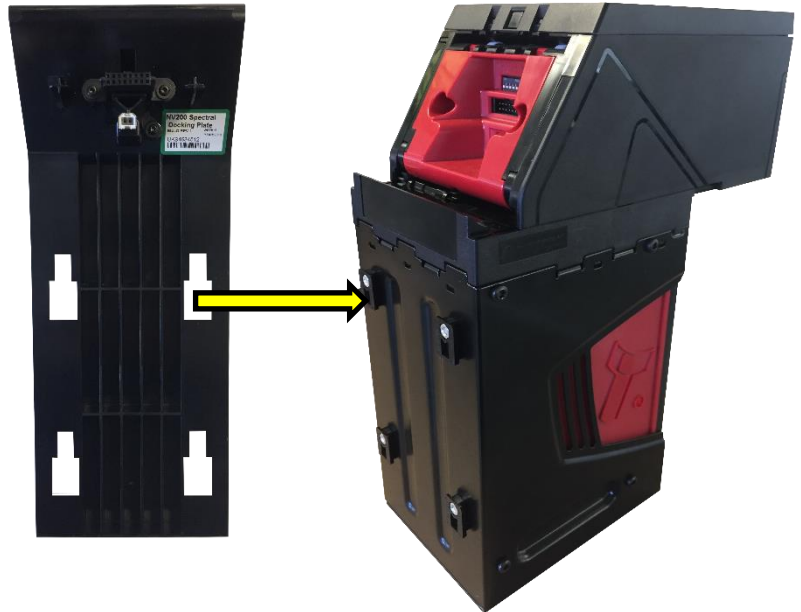

3. Lock Docking Plate in place

Press downwards on the docking plate to lock it into place on the chassis



4. Dock the NV200 Spectral head

Firmly push the NV200 Spectral back along the chassis until it locks into place on the docking plate connectors.



[<< Back to Contents](#)

4.7 Loading paper into the Smart Ticket

4.7.1 Roll

4.7.1.1 Top

The Roll paper is mounted orientated such that the paper edge goes straight from the roll into the Printer, as shown in the picture below.

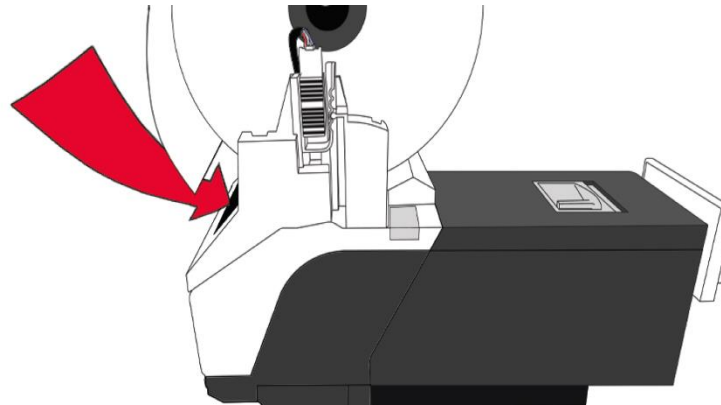

4.8 Machine Mounting

The NV200 Spectral can be mounted in a range of different methods; when changing between the standard cashboxes and TEBS cashbox the change in dimensions will need to be accounted for. See [Section 4.8.1](#) and [Section 4.8.2](#) below which shows the different mounting point options.

4.8.1 Machine Mounting – Standard Cashbox

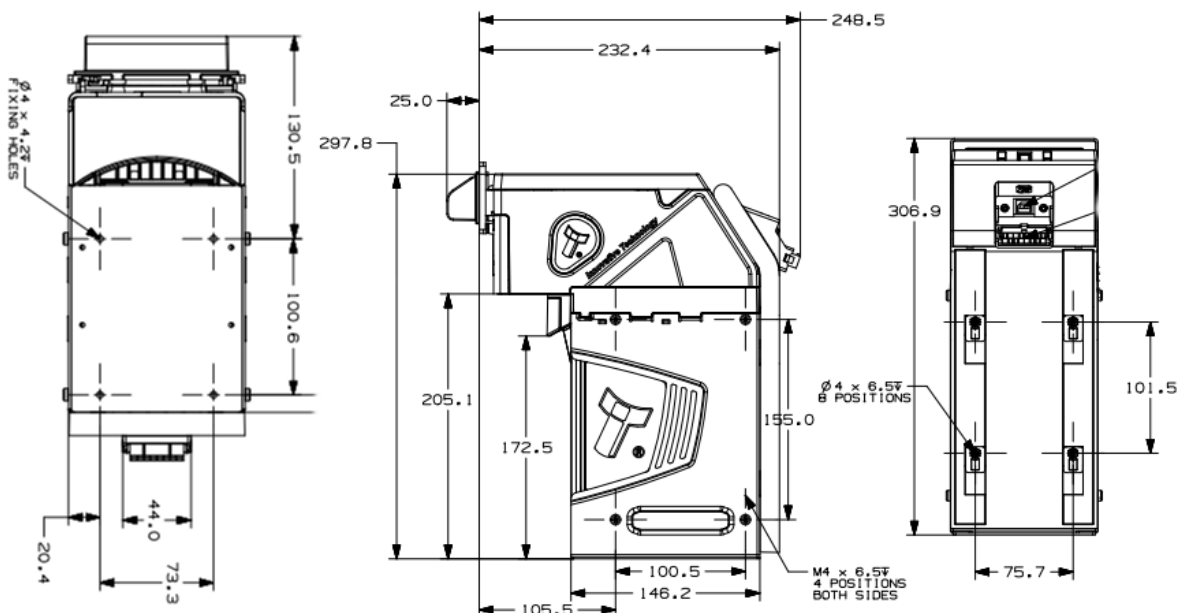

[<< Back to Contents](#)

4.8.2 Machine Mounting – TEBS

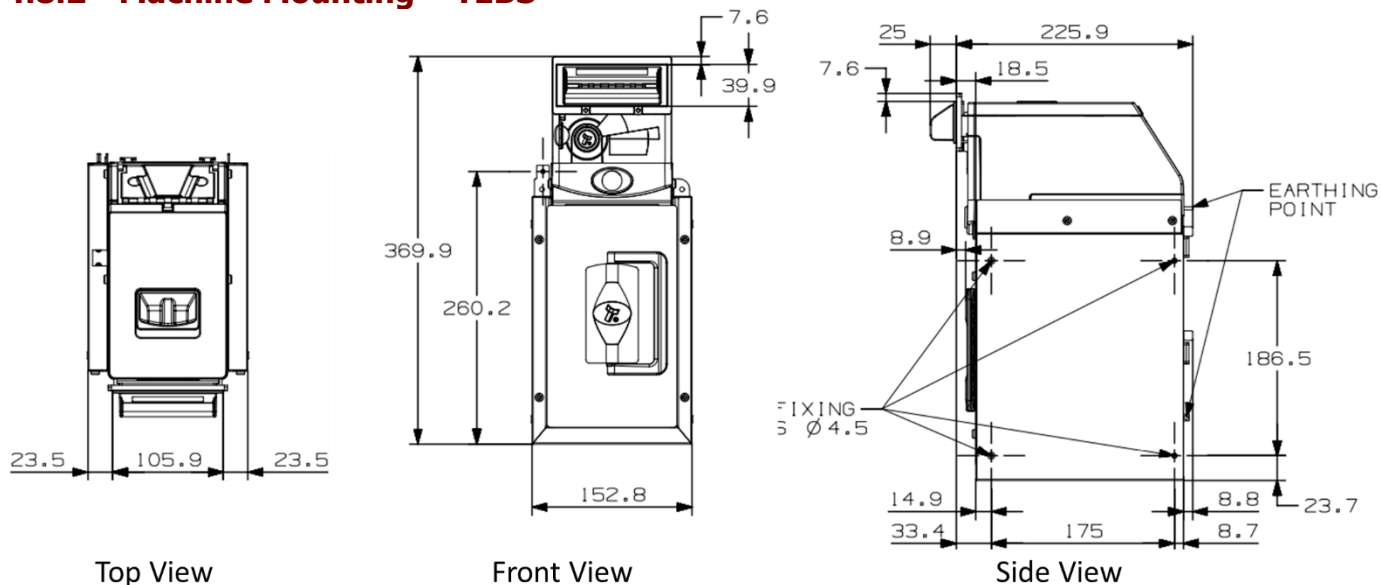

4.8.3 Earth Bonding

It is very important that the NV200 Spectral is properly bonded to earth, using one of the earth tabs. Earthing on the standard chassis can be affixed to any of the screw mounting points at the side of the unit:



[<< Back to Contents](#)

The TEBS cashbox has earthing points at the back of the chassis as shown below. The plating on the chassis must be broken to create a proper earthing point on the chassis, it is recommended to use a cutting screw but and tool that can cut away the plating will suffice.



Lack of proper bonding can cause communication issues and other failures. The resistance between the chassis and Earth should be less than 0.7Ω .

	Caution!
Lack of proper earth bonding causes failures!	

4.8.4 Screw Specifications

The scope of delivery does not include screws for machine mounting. See table below for screw specification reference.

Location	Thread Type	Screw Length
Bezel	M3	12mm
Cashbox	M4	6mm
TEBS Cashbox	M4	16mm

4.8.5 Things to consider

When mounting an NV200 Spectral there are several things to consider including:

- Smart ticket – minimum distance surrounding the validator/ticket module.
- Weight of a fully loaded unit as defined in [Section 3.2](#)
- Accessibility – allow enough space to reach all connectors and switches if required.
- Cable management – ensure no connectors are damaged/removed from everyday use.



5 SOFTWARE INSTALLATION AND CONFIGURATION

5.1 Introduction

The NV200 Spectral leaves the factory programmed with the latest dataset and firmware files, unless specifically requested. However, it is important to ensure your device is kept up to date with the latest dataset and firmware. This section will give you a brief overview of the various update possibilities with the NV200 Spectral. For detailed instructions refer to the relevant manual package supplied with the software or contact support@innovative-technology.co.uk.

5.2 Software Downloads

All software from Innovative Technology Ltd is free of charge and can be downloaded from the website www.innovative-technology.com/support/secure-download once registered and logged in. If you are not registered, create an account via the Create an account form. A confirmation email will be sent to the registered email address once all contact details have been successfully submitted.

5.3 Drivers

The ITL drivers allow you to connect any of our validators to a compatible Windows device. If you are connecting via an IF17 then you will not need to follow this process as they are signed Microsoft Drivers and should install automatically. If this isn't the case or your computer is disconnected from the network, there is a standalone package included within the driver downloads.

5.4 Dataset/Firmware Programming

5.4.1 Validator Manager

5.4.1.1 General Description

Validator Manager is a utility which allows the user to reprogram any of ITL's validators, hoppers as well as coin and note recycler. Note that admin rights are required during installation. The validator must be in SSP for the Validator Manager to detect the device.

5.4.1.2 System Requirements

- .Net Framework 4.5
- 256mb ram
- 50mb hard disk free
- Connected NV200 Spectral with active com port

	Caution!
We have seen instances where one of the dll's (itdata1.dll) used in Validator Manager are flagged as a Trojan, this is a false positive and if this happens you will need to add a rule to your antivirus to allow the file to run.	



[<< Back to Contents](#)

5.4.1.3 Hardware Setup

The connection example below shows a direct USB connection between the NV200 Spectral and the host machine (PC). This should only be used for programming/testing. For other connection examples see [Section 6.4.3](#)

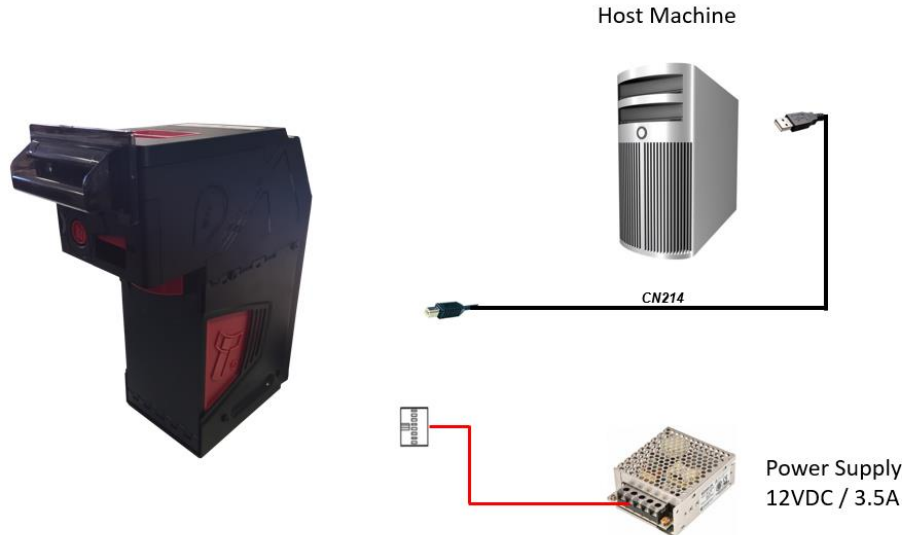

5.4.1.4 Switching to Programming Mode (SSP)

Before programming via the Validator Manager, the NV200 Spectral needs to be switched to its programming mode (SSP interface). Refer to [Appendix 11.5](#) for the procedure for doing this.

5.4.1.5 Programming the device

Once you have switched the unit into SSP, open Validator Manager and click detect devices. This will scan all active com ports for a unit, if the NV200 Spectral fails to connect ensure the correct drivers are installed and the unit is in SSP.



User Manual – NV200 Spectral

[<< Back to Contents](#)

By selecting the Program tab, you can reprogram the NV200 Spectral. To begin the upload, click open file, then browse to the file location (usually Downloads) before clicking OK.

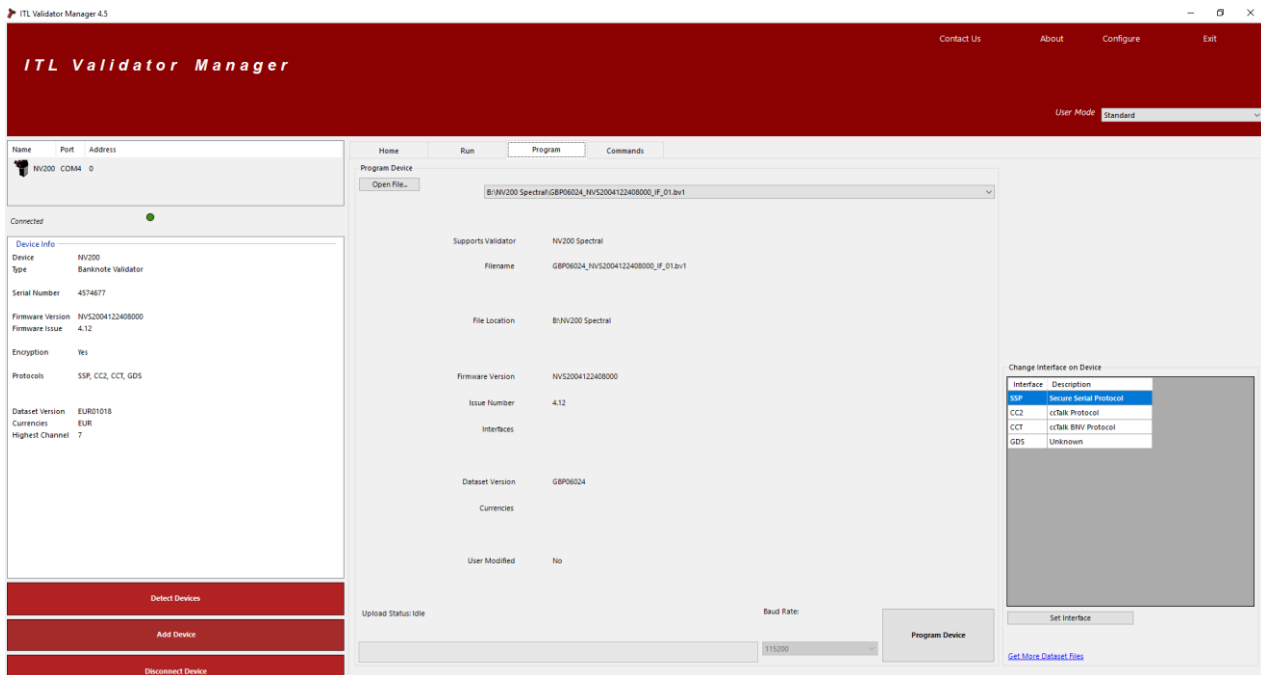

Once the file has been selected its information will be populated and the Program device tab will become active. Finally, hit 'Program Device', the unit's bezel will now begin to flash signaling the update has begun.

Caution!

Interrupting the download process can result in the unit entering a non-functional state, once the process has started it cannot be halted.

When completed the unit will restart and a pop-up box will appear saying Device Programming Complete.

5.4.2 SD Card

5.4.2.1 General Description

The NV200 Spectral can also be reprogrammed through the SD slot on the front of the unit. To do this the SD card must be correctly formatted and meet the hardware requirements defined in [Section 5.4.2.2](#) below.

5.4.2.2 Hardware Requirements

The SD card must meet the following hardware requirements:

Minimum: 4GB – Class 4

Maximum: 32GB – Class 10

The following SD card has been tested and recommended for best performance:
<https://www.sandisk.co.uk/home/memory-cards/sd-cards/ultra-sd>



5.4.2.3 Re-programming via SD Card

Follow the steps below to set up the SD card and perform the update:

- 1) Connect the SD card to your PC using an SD card reader.
- 2) Ensure that the card is FAT-32 formatted and is blank.
- 3) Create a folder on the SD card called nv200hs. **This must be lowercase**
- 4) Inside the folder, place the dataset file that you want to load on to the validator. Datasets can be downloaded from the [Innovative Technology website](#) or requested from our support team:
support@innovative-technology.co.uk
- 5) Ensure the NV200 Spectral is powered on and has booted up
- 6) Insert the SD card into the slot on the front. The bezel will now start flashing. **Do not unplug the validator during the update process.**
- 7) Wait until the bezel lights solid green. When it does, the SD card can be removed.
- 8) After the SD card has been removed, the unit will reboot. This takes around 10 seconds. Once it has rebooted the NV200 Spectral will have the new dataset on it and is ready to be used. **If there are modules attached (Payout/Ticket/TEBS) these will then be updated by the NV200 Spectral, do not unplug the unit during these updates.**

5.4.3 Remote Updates

5.4.3.1 General Description

The unit can be updated through an SSP command which sets the validator into an update mode before downloading the firmware file. Details of how this process is implemented can be found in ITL's eSSP Implementation Manual (GA973) and is available on request.

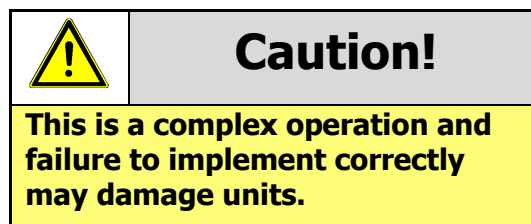

6 PROTOCOLS AND INTERFACING

6.1 Introduction

The NV200 Spectral supports standard industry protocols. Interfaces that are not listed may be available upon request. For any queries regarding interfaces that are not listed contact support@innovative-technology.co.uk

	Caution!
The use of an encrypted protocol (preferable eSSP) is strongly recommended to achieve the highest security!	

6.2 Interface Connectors

The NV200 Spectral validator has two connectors that are used to allow interfacing and programming; these connectors are easily accessible at the back of the validator.

	Information
Power always required regardless of connection type.	

Power is always required on pins 15(+V) and 16(0V) of the 16-way connector.

The first connector is a 16-pin socket used to interface the NV200 Spectral to the host machine. The pin numbering of the socket is shown below, as well as an overview of the socket connections:



When a Payout, Ticket Module or Docking Plate is connected a 16-pin Molex 0039012165 connector will replace the 16-pin Molex 9733272, the Pinout is below:



[<< Back to Contents](#)

The USB connector is a standard Type 'B' USB socket which can be used for programming the NV200 Spectral – a USB 2.0 compliant Type 'A' to 'B' lead can be used to do this. The USB connection is not recommended for use in the final 'live' application.

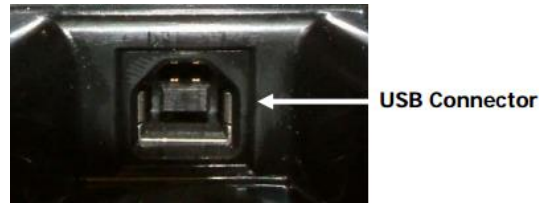

6.3 User Interfaces

6.3.1.1 Dip Switches on the NV200 Spectral

The NV200 Spectral has a Dual Inline Package (DIP) switch bank that is used to set the various options for the unit. A summary of the switch options is shown below:



Switch	Option	Switch OFF (↓)	Switch ON (↑)	Default Setting
1	Disable Barcode	Read enabled	Read disabled	OFF
2	Channel 1 Inhibit	Channel enabled	Channel disabled	OFF
3	Channel 2 Inhibit	Channel enabled	Channel disabled	OFF
4	Channel 3 Inhibit	Channel enabled	Channel disabled	OFF
5	Channel 4 Inhibit	Channel enabled	Channel disabled	OFF
6	Channel 5 Inhibit	Channel enabled	Channel disabled	OFF
7	Channel 6 Inhibit	Channel enabled	Channel disabled	OFF
8	Protocol Select	*Switches between the primary (selected) protocol and SSP (used for Programming). The switch needs to be toggled ON and OFF to alternate between the two. This will cause the unit to reset.		OFF

6.3.1.2 Dip Switches on the Payout module

The SMART Payout unit has a Dual Inline Package (DIP) switch bank that is used to set the various options for the unit. A summary of the switch options is below:

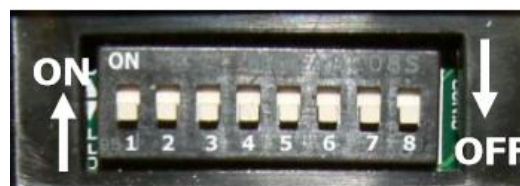

[<< Back to Contents](#)

Switch	Option	Default Setting
1-6	Not Used	OFF
7	Prevents the NV200 Spectral from updating the payout module	OFF
8	Forces the diverter to close (unit must be powered)	OFF

6.3.1.3 Smart Ticket Button

The SMART Ticket Has a button on the rear of the unit.



Pressing and holding this button will lead to a test ticket being printed, this ticket will show information on Firmware and the current printer settings.

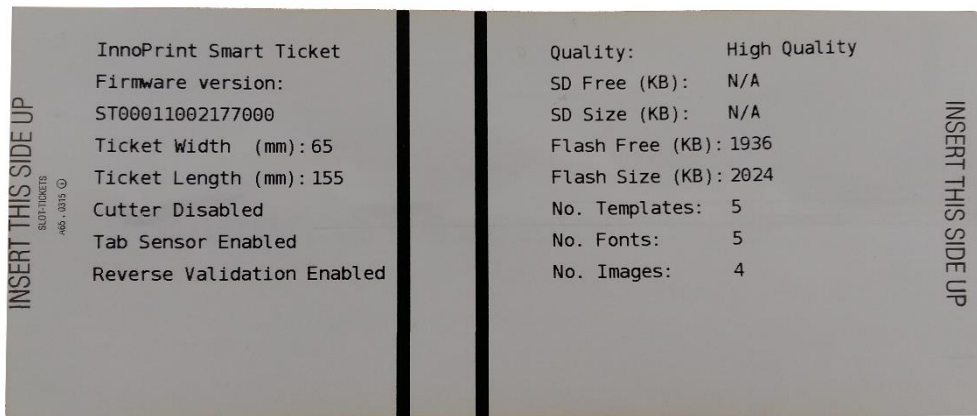

6.3.1.4 Smart Ticket Dip Switches

The SMART Ticket has 4 Dipswitches in the unit, these switches can be found by opening the Ticket path.

To open the ticket path, squeeze the clips on the top of the SMART Ticket and lift the lid.



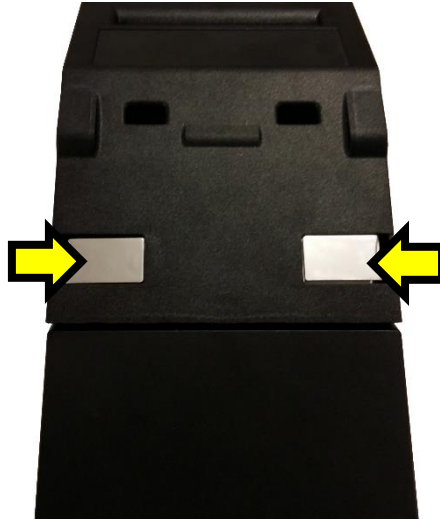

Once there is a dock of 4 dipswitches at the hinge of the SMART Ticket on the Right Side.



Switch	Option	Default Setting
1-3	Not used	OFF
4	"Safe Mode" – stops the Printer from Printing any more tickets if the Paper Low Sensor is Triggered.	OFF

[<< Back to Contents](#)

6.4 SSP and eSSP

6.4.1 General Description

Smiley® Secure Protocol (SSP) and Encrypted Smiley® Secure Protocol (eSSP) are field proven secure interfaces specifically designed by Innovative Technology Ltd. to address the problems by cash handling systems in gaming machines. Problems such as acceptor swapping, re-programming acceptors and line tapping are all addressed. This interface is recommended for all new designs. Innovative Technology Ltd. provides full SDK packages upon request including Interface Specification, Implementation Guide as well as source code examples for C++, C#.NET and Linux. Contact support@innovative-technology.co.uk for further information.

6.4.2 Pin Assignments



Pin	Name	Type	Description
1	TxD TTL	Output	Serial Data Out (Tx)
2	Factory Use Only – DO NOT CONNECT		
3			
4			
5			
6	TxD RS232	Output	Serial Data Out (Tx)
7	RxD RS232	Input	Serial Data In (Rx)
8	Factory Use Only – DO NOT CONNECT		
9			
10			
11			
12			
13			
14			
15	+ Vin	Power	+12/24VDC Supply
16	0V	Power	0V Supply (GND)

	Caution!
+12VDC/+24VDC and 0V (GND) must always be connected, also when using USB connections.	



[<< Back to Contents](#)

6.4.3 Setup Examples

The drawings below highlight how to connect the NV200 Spectral to an SSP host machine using available cables and interfaces from Innovative Technology Ltd. For cable drawings refer to [Appendix 11.1](#).

6.4.3.1 NV200 Spectral

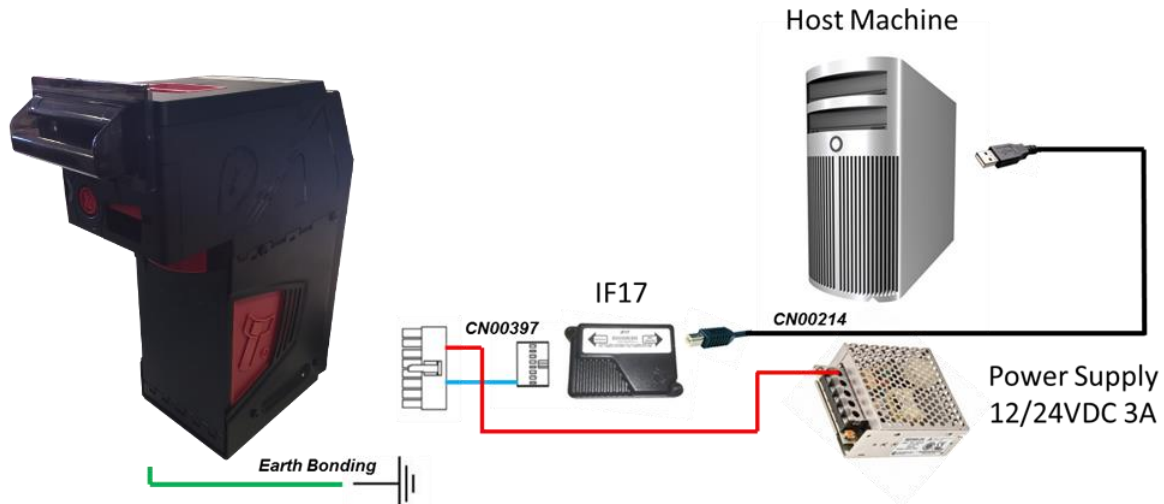

Drawing 1 - NV200 Spectral USB connection

Part Name	Description	Quantity
NV200 Spectral	NV200 Spectral Note Validator	1
IF17	USB Interface Converter /	1
WR147	SMART Payout to NV200 Spectral Adapter	1
CN398	SMART Payout to Host Cable	1
CN214	USB A to B Cable Assembly	1

Table 1 - ITL Part Numbers

Power Requirements

This setup option requires a stable 24VDC / 3.5A power supply for the NV200 Spectral according to the product specification.

Check the power requirements of your host machine and other peripherals to dimension a proper power environment for your system setup.

Caution

It is very important that the cashbox chassis of the NV200 Spectral is bonded to earth, as lack of proper bonding can cause communication issues and failures. The earth bond on a NV200 Spectral should be made to the intended connection on the outer Cashbox. The resistance between the cashbox and the Earth pin on the mains plug should be less than 0.7 ohms.



User Manual – NV200 Spectral

[<< Back to Contents](#)

6.4.3.2 NV200 Spectral and Smart Coin System

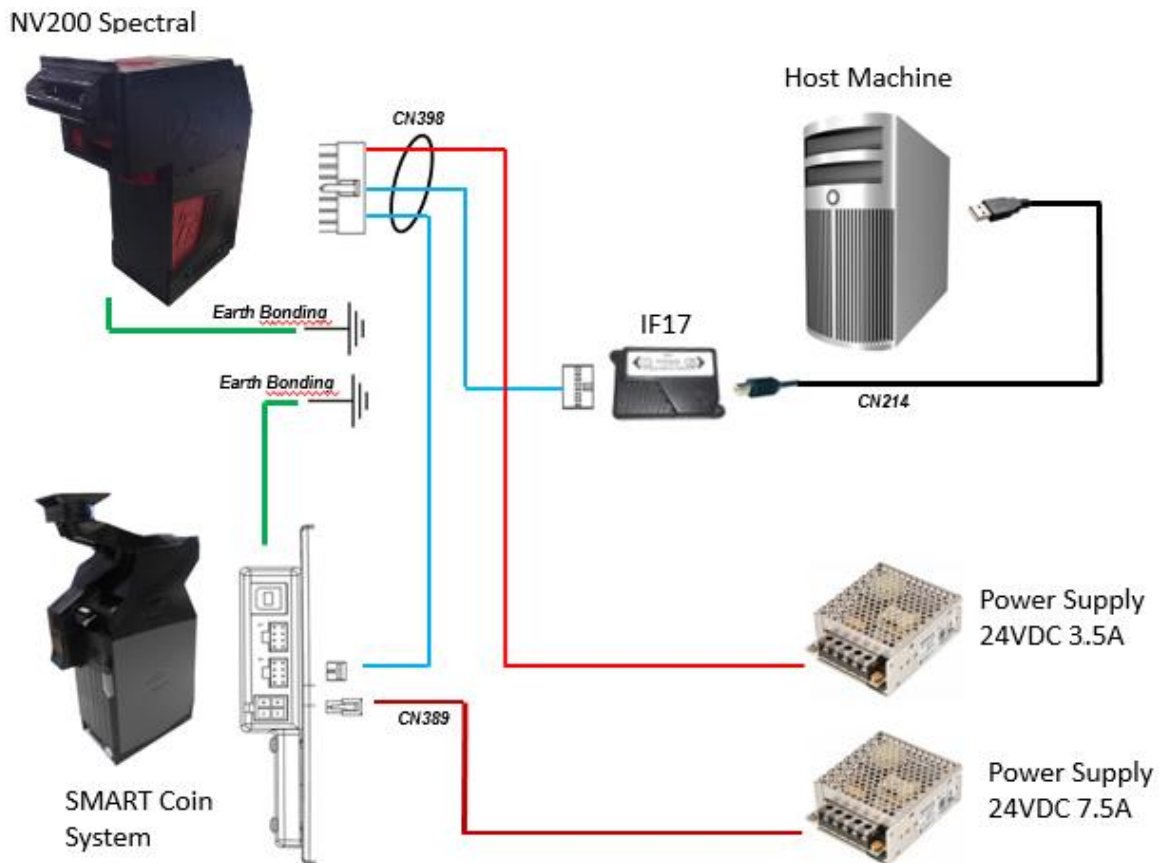

Part Name	Description	Quantity
NV200 Spectral	NV200 Spectral Note Validator	1
IF17	USB Interface Converter /	1
WR147	SMART Payout to NV200 SPECTRAL Adapter	1
CN398	SMART Payout to Host Cable	1
CN214	USB A to B Cable Assembly	1

Power Requirements

This setup option requires a stable 24VDC / 3.5A power supply for the NV200 Spectral whilst the SCS requires 24V DC 7.5A according to the product specification.

Check the power requirements of your host machine and other peripherals to dimension a proper power environment for your system setup.

Caution

It is very important that the cashbox chassis of the NV200 Spectral is bonded to earth, as lack of proper bonding can cause communication issues and failures. The earth bonds on a NV200 Spectral should be made to the intended connection on the outer Cashbox. The resistance between the cashbox and the Earth pin on the mains plug should be less than 0.7 ohms.



[<< Back to Contents](#)

6.5 ccTalk®

6.5.1 General Description

ccTalk® is a serial communications protocol designed by Money Controls to allow 3-wire interfacing between a host and cash handling peripherals.

Only the NV200 Spectral with standard cashbox and Payout module can communicate via ccTalk. The TEBS cashbox and Ticket module are currently only implemented in SSP.

Previously CC2 protocol was required to support a SMART Payout module, to implement the extra commands used for note recycling. When programmed to ccTalk the NV200 Spectral recognizes when a payout module is connected and automatically supports these extra commands, without needing to reprogram it to the CC2 protocol. For legacy support, the protocol can be locked to CC2 if required.

Contact support@innovative-technology.co.uk for further information.

	Caution!
Innovative Technology Ltd. provides full SDK packages including Interface Specification, Implementation Guide as well as source code examples for SSP and eSSP only!	

6.5.2 Pin Assignments



Pin	Name	Type	Description
1	TxD TTL	Output	Serial Data Out (Tx) (optionally link to Pin 5*)
5	RxD TTL	Input	Serial Data In (Rx) (optionally link to Pin 1*)
15	+ Vin	Power	+12/24VDC Supply
16	0V	Power	0V Supply (GND)

***If true CCTalk communication is required**

	Caution!
+12VDC and 0V (GND) must always be connected, also when using USB connections.	



[<< Back to Contents](#)

6.5.3 ccTalk® DES Encryption

When using ccTalk® DES encryption, the NV200 Spectral and host machine must exchange a secret key which forms the basis of the communication encryption. This exchange is performed in a Trusted Mode maintaining security. The Trusted Mode can only be entered by a physical access to the NV200 Spectral. Refer to [Appendix 11.7](#) for details.

6.5.4 Setup Example Drawings

6.5.4.1 NV200 Spectral

The drawing below highlights how to connect the NV200 Spectral to a ccTalk host machine using available cables and interfaces from Innovative Technology Ltd.

This is not true ccTalk as the Tx and Rx pins are not joined, pin 1 and 5 can be connected if required.

For complete cable drawings refer to [Appendix 11.1](#).

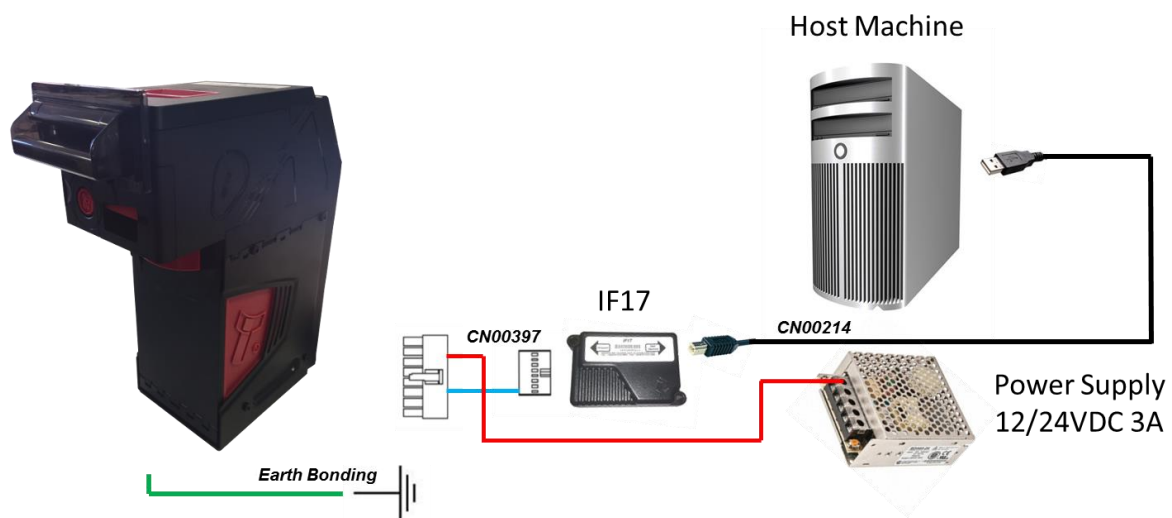

6.5.4.2 NV200 Spectral with Payout Module (SPO)

The drawing below highlights how to connect the SPO to a ccTalk host machine using available cables and interfaces from Innovative Technology Ltd.

This is not true ccTalk as the Tx and Rx pins are not joined, pin 1 and 5 can be connected if required.

For complete cable drawings refer to [Appendix 11.1](#).

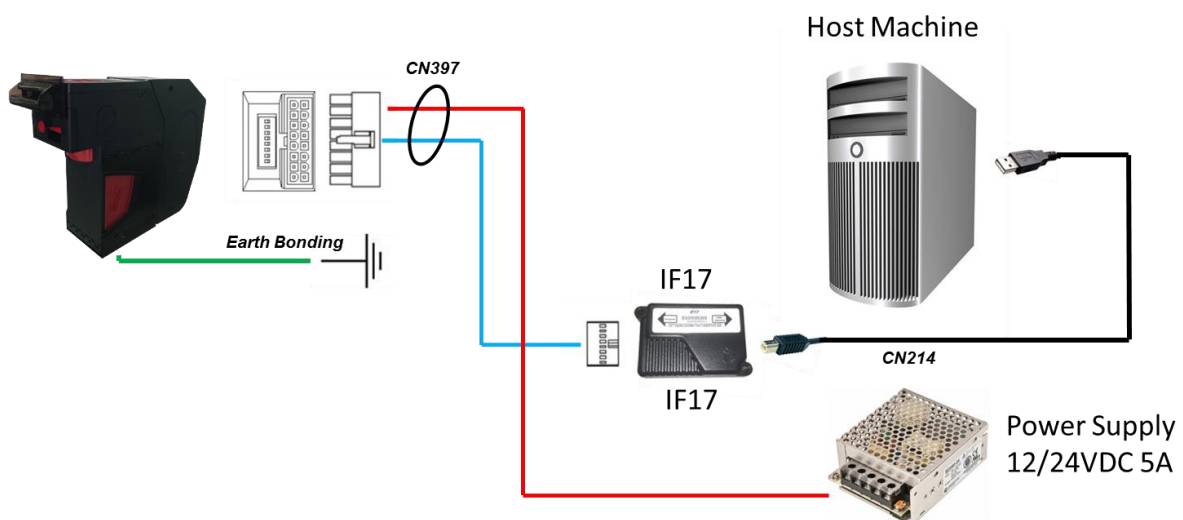

7 ROUTINE MAINTENANCE

7.1 Introduction

The NV200 Spectral has been designed to minimise any problems or performance variations over time. This has been achieved by careful hardware and software design; this attention to the design means there is very little user maintenance required.

7.2 Recommended Cleaning Intervals

Innovative Technology Ltd recommends cleaning the optical lenses every month or as required. Dirt, dust or other residue leads to bad note acceptance and other performance degradation. Refer to the section below for detailed cleaning instructions.

7.3 Cleaning the NV200 Spectral

Disconnect the power **BEFORE** carrying out any cleaning operations to avoid the risk of causing damage to the validator.

7.3.1 Cleaning the Validator



Caution!

Do not use solvent based cleaners on any part of the NV200 Spectral unit.

Do not use solvent based cleaners such as alcohol, petrol, methylated spirits, white spirit or PCB cleaner. Using these solvents can cause permanent damage to the units; only use a mild detergent solution as directed below.

The NV200 Spectral note path can be cleaned with the head still fitted to the chassis, although it may be easier to remove the head from the chassis assembly.

To remove the NV200 Spectral head unit, first lift the red head release catch located on the front of the NV200 Spectral

Finally, slide the head unit forward and lift it off the chassis

Head
release
catch



WARNING!

Disconnect power **BEFORE** any cleaning operation



[<< Back to Contents](#)

To open the note path cover, pull the top cover release latch forward (towards the bezel) and lift the cover as shown below (it is recommended to also remove the bezel to allow correct cleaning of the note path guides):



The note path is visible and can be cleaned. Carefully wipe the surfaces with a soft lint free cloth that has been dampened (NOT wet) with a water and mild detergent solution (e.g. household washing up liquid) - be very careful when cleaning around the sensor lenses and make sure they are clean and dry before closing the cover and powering the unit.

 **Caution!**
Do not use any lubricants.

Do not lubricate any of the note transport mechanism or any part of the note path, as this can affect the operation of the validator.

 **WARNING!**
Do not try to disassemble

Do not attempt to disassemble the validator head – trying to do this could cause personal injury and will damage the unit beyond repair.

7.3.2 Cleaning the TEBS Cashbox

Remove the cashbox as this provides access to the moving parts within the TEBS cashbox. Once the cashbox has been removed, detach the NV200 Spectral head this provides access to the drive gears.

Manually turn the stacker drive this will move the stacker forward, when at the full extension there is a tactile bump. This will hold the stacker out allowing compressed air (Max pressure = 5 bar) to be blown into the unit.



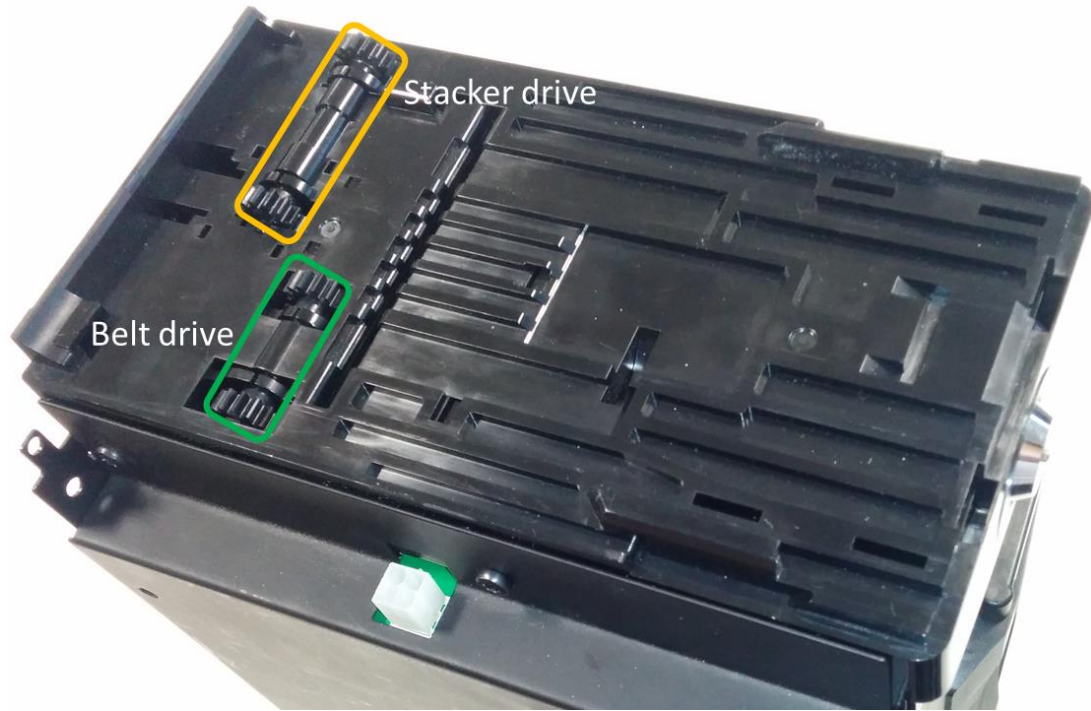

Once the debris has been cleared check foam strips on the stacker to ensure they are not damaged, if not move the stacker back into the rest position. If they are damaged, remove the stacker plate by pushing up and replace the strips with ITL part number LB2034.

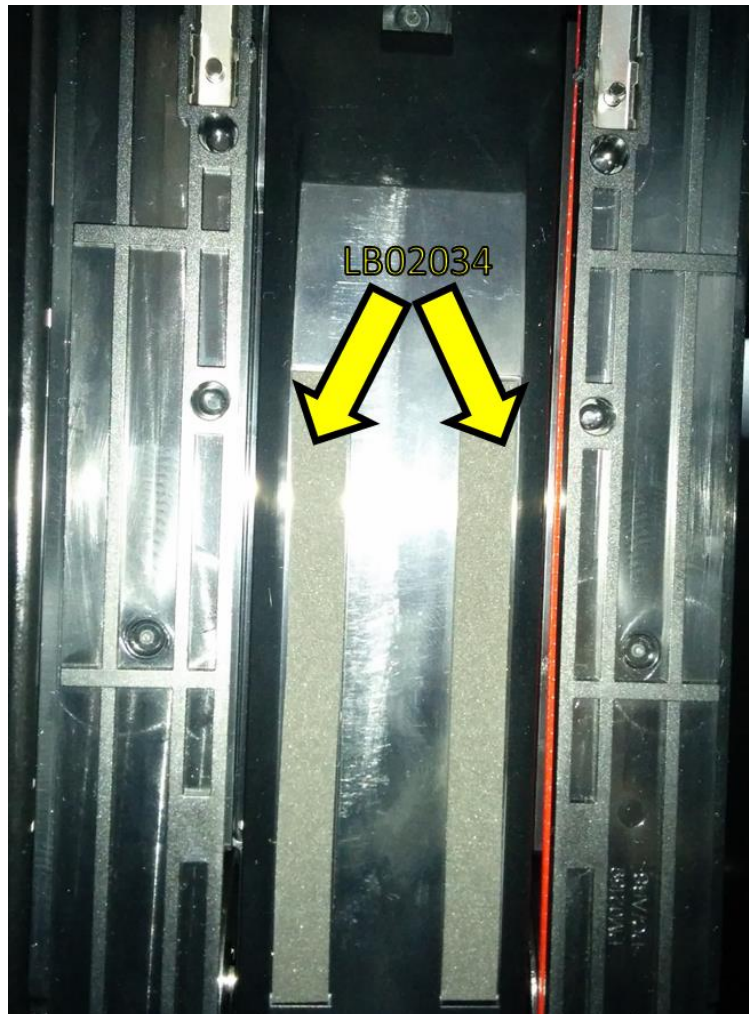

7.3.3 Cleaning the Ticket Module

To Clean the Ticket module, open the printer by squeezing the clips on the top of the SMART Ticket and lifting the lid.

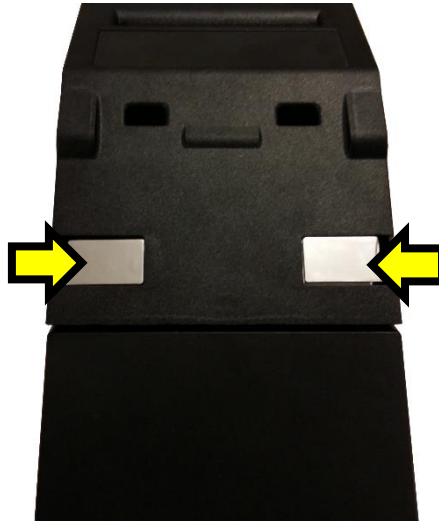

When opened the ticket path is accessible, as shown below:



Part of the SMART Ticket needs to be removed so the whole path can be cleaned.

The PM01018 is used to guide the paper, the part is shown in situ below.

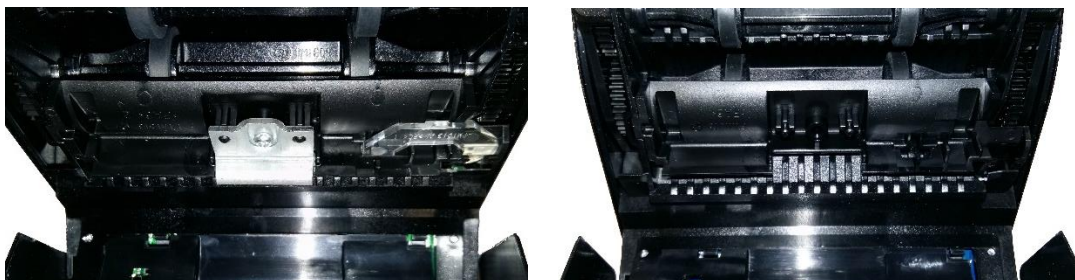

Remove this part by pressing into a lug on the side with a tool (e.g. a screwdriver) and lifting the PM01018 out of position.



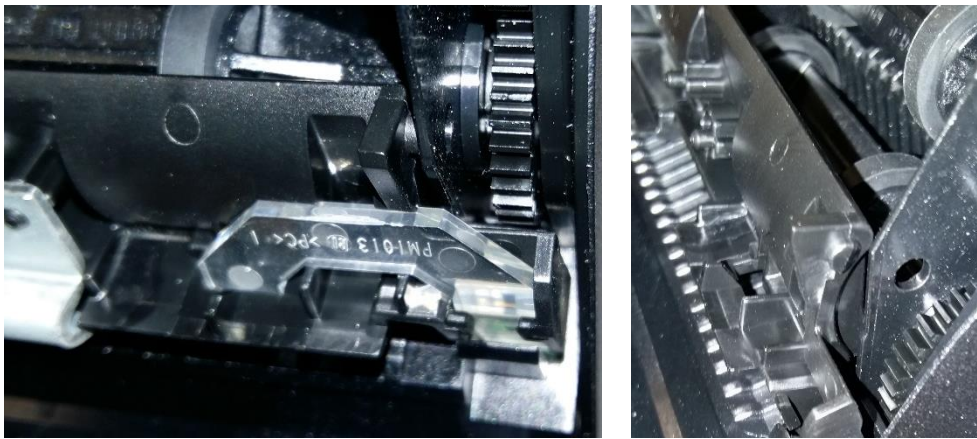
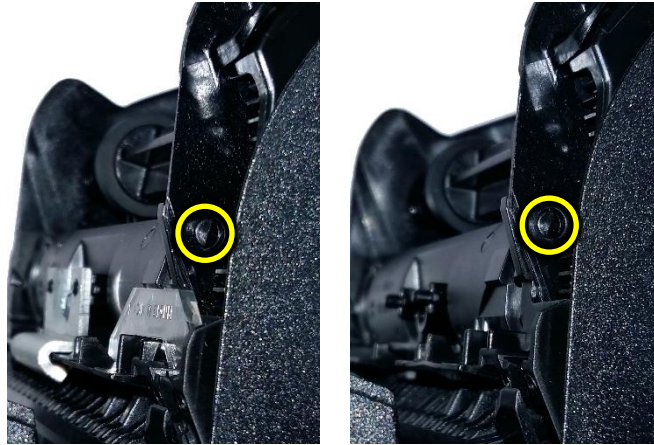

There are Lugs on both sides, when one is unclipped, the other can be removed.

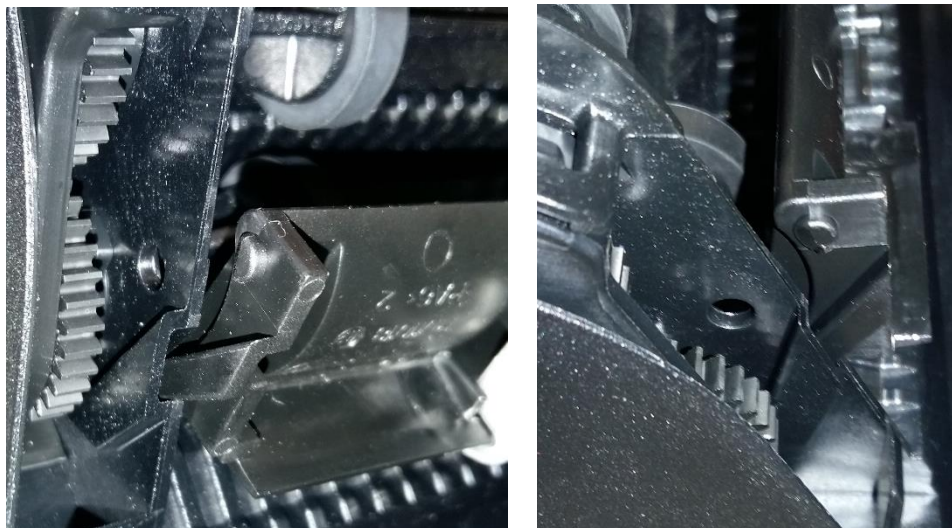

It can then be lifted out of position to reveal the rest of the ticket path.



Compressed air (Max pressure = 5 bar) should be used to clean the rollers and ticket path of debris. The ticket path can then be wiped off with a soft lint free cloth, this can be dampened (NOT wet) as required.

The printer should be opened so the cutter can have debris removed.

Pushing back on the white lever will pop the printer platen out of position.



Both the Printer body and the platen (the removed part) can be wiped off with a dampened (NOT wet) soft lint free cloth.

The Platen is reattached by pushing it back into position.

The detached plastic for the note path can be repositioned by aligning the plastic guides and pushing the nodules into position.

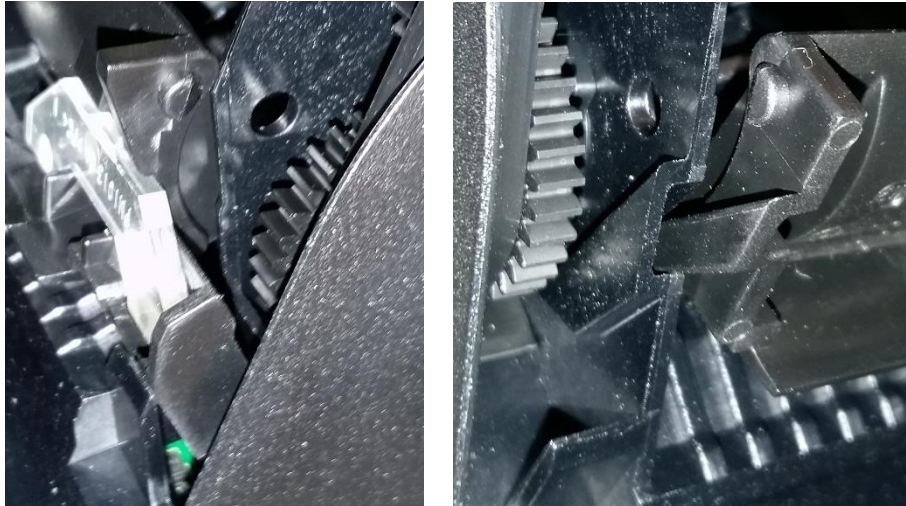

The Ticket Path can then be closed, and the unit can be powered.

8 FIRST LEVEL SUPPORT

8.1 Bezel/Status LED Flash Codes

The NV200 Spectral Validator has inbuilt fault detection facilities. If there is a configuration or other error, the NV200 Spectral front bezel will flash in a particular sequence, and a summary of the Bezel Flash Codes for the NV200 Spectral is shown below:

Flashes		Indicated Status / Error	Recommended Action
Red	Blue		
1	1	Note Path Open	Close the lid of the NV200 Spectral validator it will click into place as it shuts.
	2	Note Path Jam	<ol style="list-style-type: none"> 1. Power down the NV200 Spectral 2. Open the NV200 Spectral using the red catch on top and inspect the note path for any note debris 3. If there isn't any evidence of a note carefully remove the NV200 Spectral from the base using the red catch on the front. 4. A note could be just sticking out from the cashbox, remove power and the NV200 Spectral head. 5. If a note is visible remove the note. 6. Re-attach the head and power. 7. If the jam isn't cleared remove the cash bag as described in Section 4.3
	3	Unit Not Initialised	The NV200 Spectral will need to be returned to your nearest repair centre for repair
2	1	Cashbox Removed	<p>Insert the cashbox.</p> <p>If it is a TEBS cashbox and the error is displayed with the cashbox inserted, remove the outer housing and check the barn door flag is operating</p>
	2	Cashbox Jam	Follow the steps as advised in Section 9.2
	3	No TEBS Detected	<p>Remove the NV200 Spectral head by lifting the red latch on the front of the unit. Replace the unit ensuring the NV200 Spectral is flush with the front of the TEBS unit.</p> <p>If the unit is displaying this error but is connected to a standard cashbox the NV200 Spectral cashbox flag should be changed in Validator Manager. If this doesn't solve the issue attempt a power cycle of both the NV200 Spectral and TEBS.</p>
	4	Barcode Fail	<p>If a new bag had been inserted and the unit fails to read the barcode; attempt a power cycle of the TEBS base by removing and replacing the 4 pin Molex on the left-hand side of the unit.</p> <p>If the unit doesn't recover a new bag will need to be inserted, replace the bag as outlined in Section 4.4</p>



User Manual – NV200 Spectral

[<< Back to Contents](#)

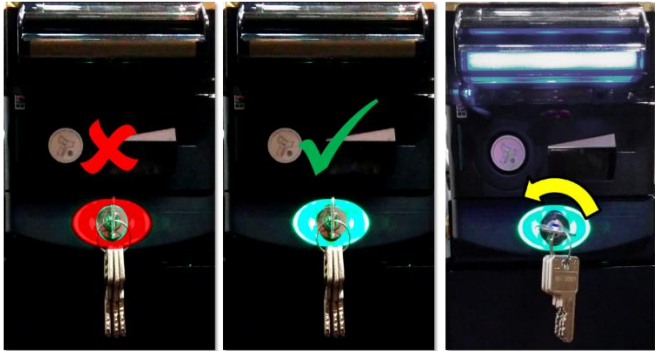
	5	Cashbox Unlocked	Issue an unlock command to the TEBS, physically unlock and relock the unit ensuring the lock has been completely turned.
			
	6	Currency Mismatch	Remove the current TEBS bag and reinsert a new bag.
	7	Firmware Error	Contact ITL support.
3	1	Firmware Checksum Error	There has been an issue with the attempted download, retry the download with the recovery section on validator manager, if this fails arrange for the unit to be returned to the nearest repair centre; details of which can be found on our website.
	2	Interface Checksum Error	The firmware loaded doesn't contain the primary interface from the previous firmware. Download with the IF file containing the correct protocol.
	3	EEPROM Checksum Error	There has been an issue with the attempted download, retry the download with the recovery section on validator manager, if this fails arrange for the unit to be returned to the nearest repair centre; details of which can be found on our website.
	4	Dataset Checksum Error	
4	1	Power Supply too Low	Check the voltage on your power supply is within the specified voltage range as outlined in Section 3.4 If the voltage appears to be correct, check to ensure the power supply voltage doesn't vary by more than 10% under maximum current draw.
	2	Power Supply too High	Check the voltage on your power supply is within the specified voltage range as outlined in Section 3.4 If the voltage appears to be correct, check to ensure the power supply voltage doesn't vary by more than 10% under maximum current draw.
	3	Card Format	The data card inserted is incorrect, format the card using the latest NVCardUtilities.
	4	Payout Reset	The Smart Payout is in the process of resetting, wait for it to recover.



[<< Back to Contents](#)

5	1	Firmware Mismatch	The Firmware on the device connected doesn't match the firmware on the NV200 Spectral. Ensure the Firmware supports the connected device. If a payout is connected, ensure Dipswitch 7 is off.
	2	Payout Jam	The smart payout has encountered an issue and a note has jammed, follow the steps as described in Section 9.4
	4	Payout Jam recovery in progress	The smart payout encountered a jam and is attempting to recover. 5 notes will be moved to the cashbox, from the payout. Once the unit has completed this it will go back in service.

8.2 NV200 Spectral Module Flash Codes

Each additional module for the NV200 Spectral has its own flash codes, outlined in the subsections below.

8.2.1 TEBS Lock Flash Codes

The TEBS cashbox can display a flash code on the lock cam.

Flashes		Indicated Status / Error	Recommended Action
Red	Blue		
3	2	Camera not Responding	Arrange for the unit to be returned to the nearest repair centre; details of which can be found on our website.
3	3	EEPROM Error	
3	4	TEBS Log CRC Error	Send the Clear TEBS Log command through validator manager this will reset the logs and the error should clear.

8.2.2 Payout Module Flash Codes

An LED on the rear of the payout module can flash error codes to aid troubleshooting.

Status Indicators		Flashes	Indicated Error	Recommended Action
Red	Green			
		0	No LEDs lit	Ensure the required power is being provided
●		1	Motor / barcode error	Arrange for the unit to be returned to the nearest repair centre; details of which can be found on our website.
		2	Note sensor error	
		3	EEPROM error	
		4	Payout jammed	Remove trapped note (see Section 9.4 of this manual set)
		5	Diverter error	Switch Payout module DIP switch 8 on and off with power on (diverter position shown in Section 9.5)
●	●	0	Both LEDs on (no flash)	Turn power on and off
		1	Power reset	Providing information, not an error.
		2	Wakeup from low power	Providing information, not an error.
		3	Software reset	Providing information, not an error.
		4	Software command	Providing information, not an error.
		5	User manual reset	Providing information, not an error.
		6	Power supply issue	Check power supply is within specification as outlined in Section 3.4 .
		7	Unknown cause	Ensure the unit is grounded.
	●	1 every second	None	Providing information, not an error.



8.2.3 Ticket Module Flash Codes

The Button on the Rear of the SMART Ticket can flash Error codes to aid trouble shooting.

Flashes		Indicated Error	Recommended Action
Red	Yellow		
	Flashing	No Issue	Providing information, not an error.
Solid	Flashing	Paper Low	Refill the Tickets.
1	1	No Connection detected	1. Make sure a NV200 Spectral is connected. 2. Check the NV200 Spectral is powered. 3. Check the Firmware on the NV200 Spectral supports the SMART Ticket.
	2	Initialisation Fail	Contact repairs@innovative-technology.com.
	3	No Print Head	Reattach printer.
	4	Ticket Path Open	Shut the SMART Ticket.
2	1	No Paper	Insert paper into the printer
	2	Tab not found	Ensure the Fan Fold paper is inserted the correct way around.
	3	Load fail	1. Ensure there is nothing blocking the paper entering the printer and reinsert the paper. 2. Remove the printer platen see Section 7.3.3 , move the paper feed roll, reinsert the platen and reinsert the paper.
3	1	Diverter not opened	Ensure the NV200 Spectral diverter plunger isn't covered and there is nothing stopping the SMART Ticket Actuator from opening.
	2	Diverter not closed	Ensure there is nothing holding the diverter plunger down and there is nothing stopping the SMART Ticket Actuator from closing.
	3	Burst fail	Open the Ticket Path and remove the ticket that failed to print. Ensure the unit is clean and PA01132 is fitted correctly.
	4	Cut fail	Open the ticket path and remove the ticket that failed to print. Ensure the printer is clear of any debris or blockages.
	5	Unknown jam	See Section 9.6 for information on how to clear jams.
4	1	Unknown error	Reset the unit.
	3	Card Format	The inserted card must be in a Fat 32 format remove and format the card.

8.3 Checking power connections to the unit

Check to ensure the power cables are correctly connected to the unit as shown in the sections below.



[<< Back to Contents](#)

8.3.1 NV200 Spectral Connections

Ensure the NV200 Spectral has power applied, the pin-outs for the relevant connection can be found in [Section 6.4.2](#)

The NV200 Spectral connector and the IF17 connector are similar, the only difference is the power cables in pins 15 & 16 on the NV200 Spectral connector.



8.3.2 TEBS Connections:

Ensure both the NV200 Spectral and TEBS cashbox have power applied

The NV200 connector and the IF17 connector are similar, the only difference is the power cables in pins 15 & 16 on the NV200 connector.

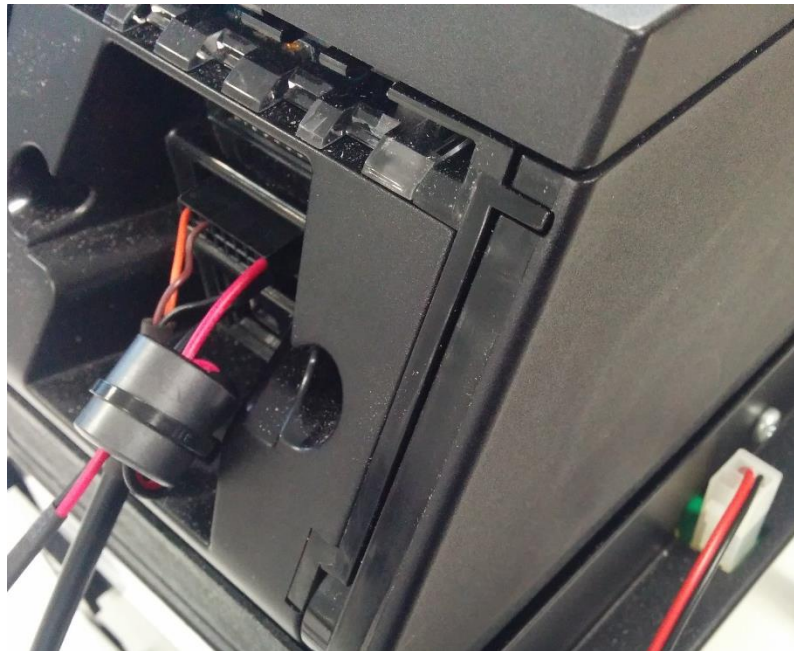

[<< Back to Contents](#)

8.3.3 Smart Payout Connection:

The Payout module connector is a 16-pin molex as outlined in [Section 6.2](#), ensure the cable is correctly seated.

If the TEBS cashbox is fitted it also needs to be connected to power as explained in the section above.



8.3.4 Smart Ticket Connection:

The SMART Ticket uses the same 16 pin molex connector as the SMART Payout, additional pins need to be populated to carry communications to both the NV200 Spectral and printer. More details of this can be found in [Section 6.2](#)

An additional 4-pin molex connector is required for power, both must be connected before the unit will identify as a Smart Ticket. When power is supplied to the ticket the LED on the rear will be illuminated.



8.3.5 Checking the Supply Voltage

If the power supply seems to be powered and connections to the unit are in place, yet the unit isn't powered, check the voltage output from the power supply is sufficient and the polarity is correct. If this isn't the issue replace the cable as it may have been damaged. Should this not resolve the issue, contact your local repair centre, details of which can be found on our website.

8.4 Communication with the Host

If there is no communication with the host check the communication cable, typically this will be the IF17 and the port on the host system.

Ensure the cable is connected to the IF17 correctly, so the connectors are fully seated, and the USB cable is connected to the computer.



User Manual – NV200 Spectral

[<< Back to Contents](#)

If the unit is connected, enter device manager and check the active com ports, there should be a device labelled as USB Serial. If no com port is present replace the IF17 and a new device will register.

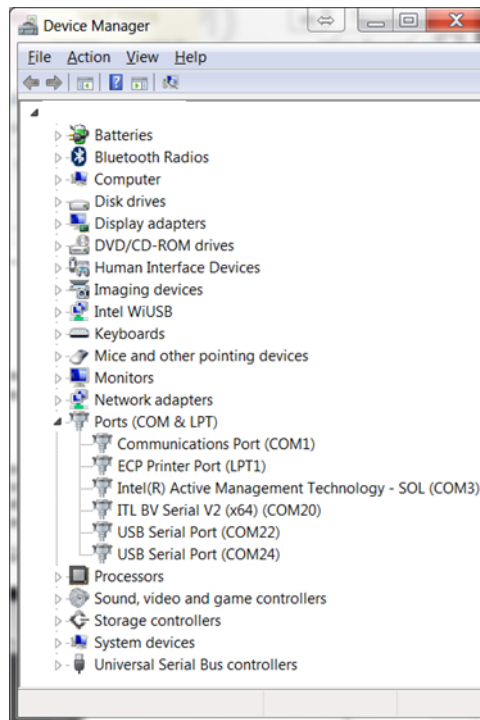

Check the connection to the host software, if there is still an issue replace the IF17 or switch com ports on the PC. If the unit is detected but there is a yellow triangle next to the serial port, then the drivers should be reinstalled.

For Linux use the dmesg console command as shown below:

```
File Edit View Search Terminal Help
james@james-VirtualBox ~ $ dmesg | grep tty
[  0.000000] console [tty0] enabled
[ 55.387744] usb 1-2: FTDI USB Serial Device converter now attached to ttyUSB0
james@james-VirtualBox ~ $
```



9 SECOND LEVEL SUPPORT

9.1 Obtaining Logs using SD Card

The NV200 Spectral has 128MB internal memory which is used to capture event and performance logs. To retrieve the logs from the internal memory, you can insert an SD card into the front slot. The SD card must be FAT-32 formatted and have an empty folder on there called **NV200HSL**. When this card is inserted the bezel will flash alternating colours, when it goes green the data transfer is complete and the SD card can be removed.

Alternatively, you can put an SD card in the slot that has two empty folders on it: **hsdata** and **valaudit**. This SD card will log all future events but does not extract logs currently stored on the internal memory. If this card is inserted all logs will be written to it instead of the internal memory.

See [Section 5.4.2.2](#) for the hardware requirements for the SD Card

9.2 Clearing a Jam from the NV200 Spectral

9.2.1 Note is in the note path

If the note is jammed in the note path it is possible to clear the jam by simply lifting the lid by pulling the catch toward you as shown in the picture below. Once the note path is clear you can then carefully pull the note out of the unit. Now shut the head and the unit should reinitialise.

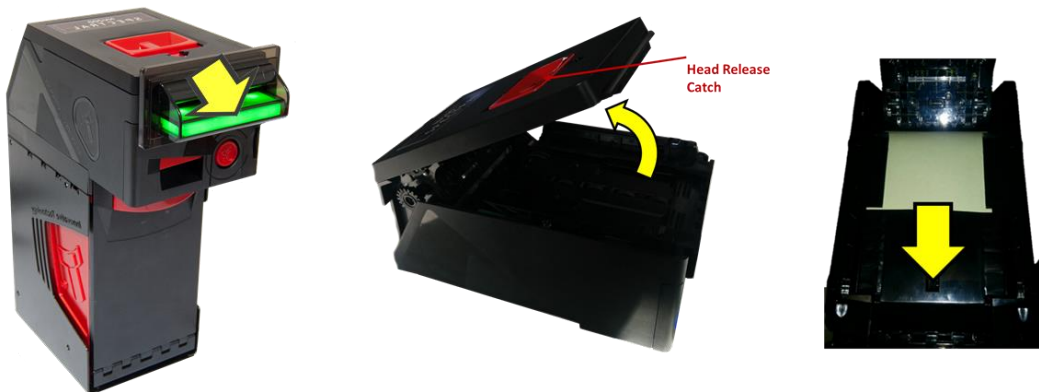

9.2.2 Note is visible once the NV200 Spectral has been removed

To clear this type of jam you will need to disconnect the power and then remove the NV200 Spectral head. Once you remove the head as explained in the picture below, check to see if the note is protruding from the cashbox. If it is, this means the note hasn't been driven down into the cashbox, this jam can be cleared by winding the drive gears on the left of the unit and slowly pulling the note out. Once the note has been removed, replace the NV200 Spectral head and reconnect the power.

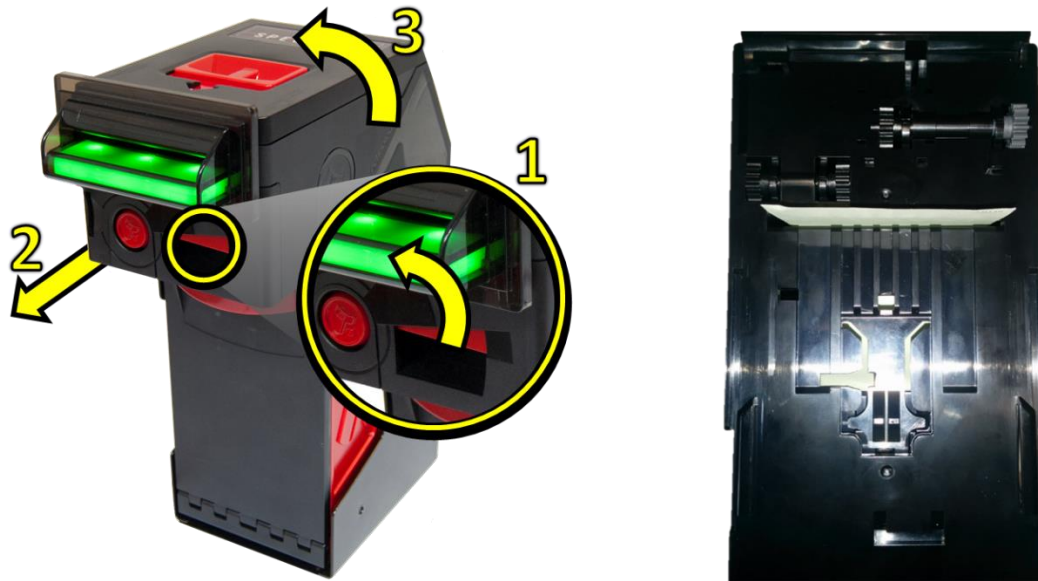

9.2.3 Note isn't visible once the NV200 Spectral has been removed

If the note isn't visible then there is a jam in the cashbox, remove the cashbox by pulling the handle on the front of the cashbox and sliding it forward. Turn the keyless lock to release the barn door, you will now have access to the cashbox to manually remove the note. Usually the note will be resting on or underneath the stack of notes and may be folded or torn. Once the note has been identified slowly pull the note out of the unit. Replace cashbox and the unit should run through internal diagnostics and then be back in service.



[<< Back to Contents](#)

9.3 Clearing a Jam from the TEBS Cashbox

Ensure the TEBS is connected to power and remove the cashbox.

When the bag is removed, the note causing the jam condition hasn't been credited so will need to be re-inserted when the unit is back in service.

The note causing the jam will be visible; typically the note will be resting on top of the pusher plate and may be folded or torn. It can be behind the push plate.

Once the note has been identified, push the doors back and slowly pull the note out of the TEBS cashbox ensuring there is no debris left behind.

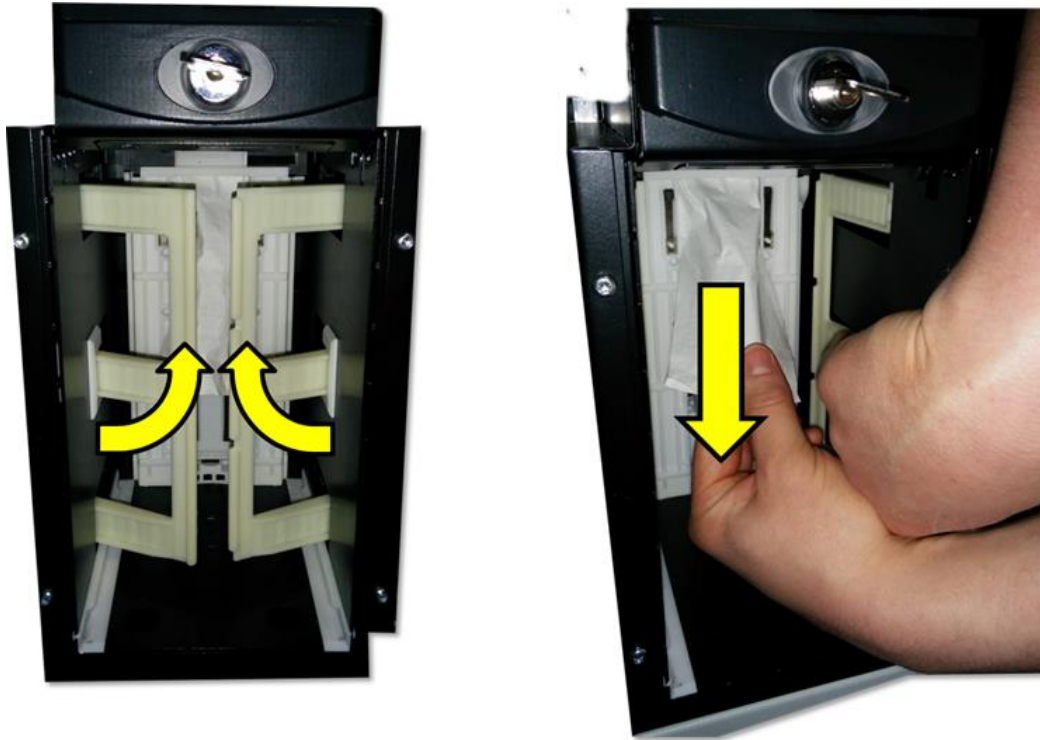

If the note is behind the stacker plate, it is still possible to recover the unit. Wind the stacker plate forward using the gears on top of the TEBS unit as highlighted below. Hold the gear in position while removing the note.

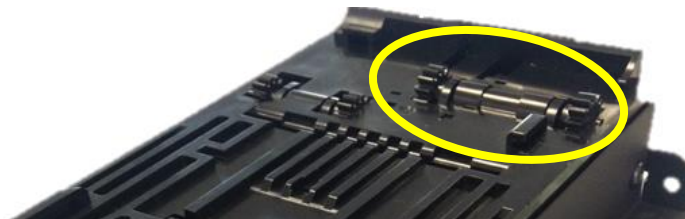

The stacker plate should sit approximately 5cm from the home position. Carefully pull the note out from behind the stacker plate and wind the plate back to its rest position.

Inspect the note when it is removed, should the note have a tear or have a piece missing it could be lodged within the unit and trigger another error. One way of checking for this is to shine a torch into the TEBS cashbox and carefully inspect the surround. Highlighted below is an example of paper located in the top of the TEBS unit, this is evident due to the white reflection on the right when compared to the left.



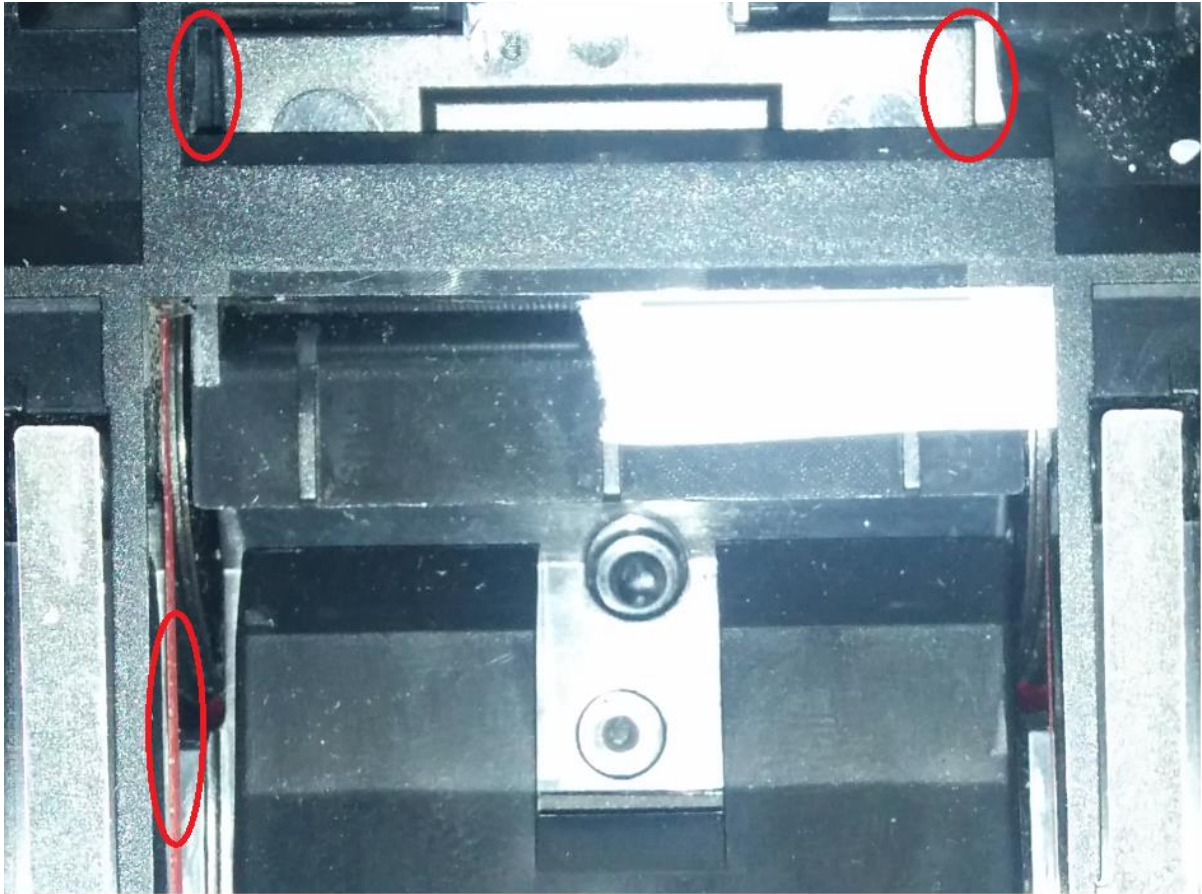

9.4 Clearing a Jam from the Payout Module

In case of a Jam in a payout, notes can be manually paid out. The payout will need to be removed from the NV200 Spectral by lifting the red catch at the front of the NV200 Spectral and sliding it away from the cashbox, it is now possible to lift the payout module away. The only tool required to carry out this process is a 5 mm Allen key.



Caution!

Risk of serious damage to payout module internal mechanism

Take great care not to overwind the mechanism or force past the dead stops – if done the payout unit will be damaged beyond repair.



Caution!

Do not use a power tool to unwind the unit this will permanently damage the unit.

User Manual – NV200 Spectral

[<< Back to Contents](#)

1. Locate the Allen key into the hexagonal Diverter slot.

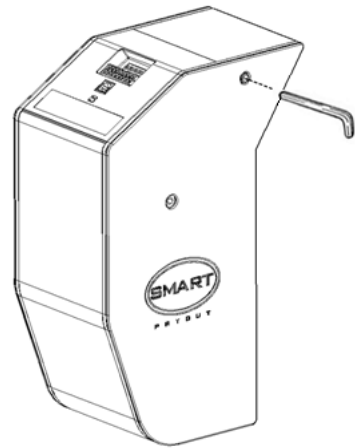

2. Move the Diverter into the transfer position by gently turning the Allen key anti-clockwise until it reaches the dead stop.

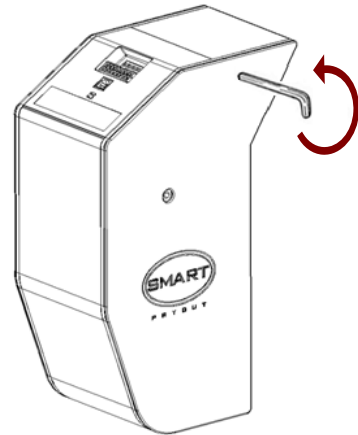

3. Locate the Allen key into the hexagonal Motor Drum slot.

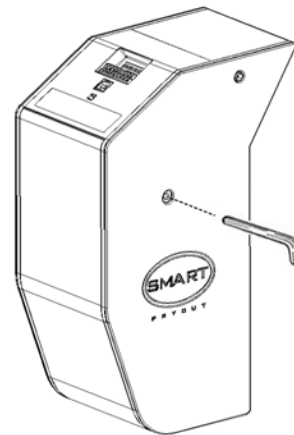

[<< Back to Contents](#)

4. Transfer all the stored bank notes onto the Transaction Drum by turning the Allen key clockwise. The barcode will be travelling towards the note exit and the bank notes will be travelling into the module.

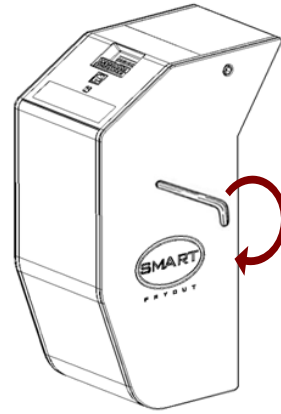

5. Once all the bank notes have been transferred to the Transaction Drum move the Diverter into the payout position by gently turning the Allen key clockwise until it reaches the dead stop.

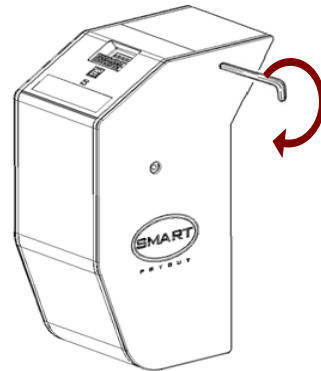

6. Pay out the stored bank notes by turning the Allen key anti-clockwise. The barcode will be travelling into the Payout module and the bank notes will be paid out through the note exit.

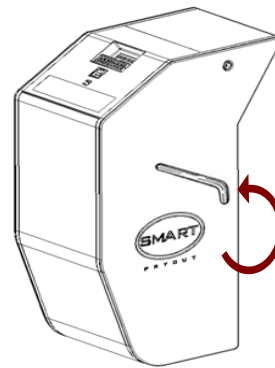

[<< Back to Contents](#)

9.5 Diverter and Tape positions in the Payout Module

The images below show the barcode tape position with the diverter in the open and closed positions.

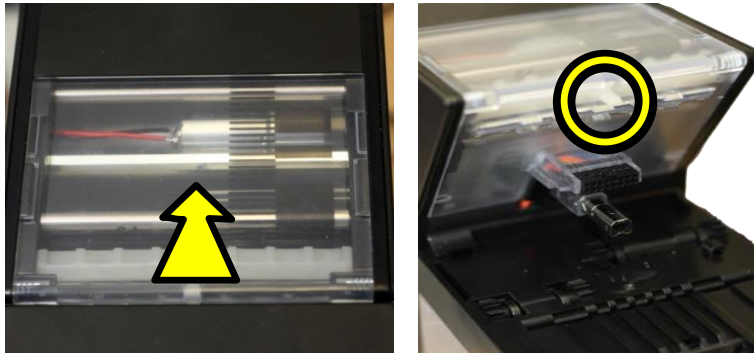

Normal tape position – diverter in CLOSED

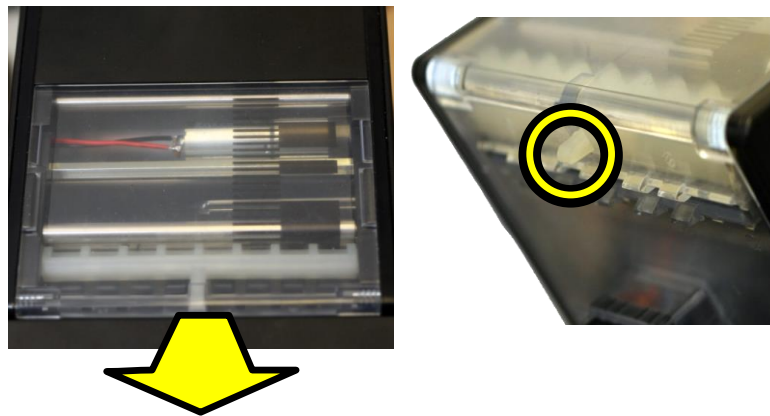

Normal tape position – diverter in OPEN position

9.6 Clearing a Jam from the Ticket Module

If a Jam has occurred in the SMART Ticket Power must be Removed, once removed disconnect the NV200 Spectral by lifting the red catch at the front of the NV200 Spectral and sliding it away from the cashbox, it is now possible to lift the Ticket module away. With the NV200 Spectral removed the Ticket Path can be opened as explained in [Section 7.3.3](#).

Remove any visible blockage then remove the loaded tickets. Ensure there is no debris built up in the SMART Ticket as explained in [Section 7.3.3](#)

Attach the NV200 Spectral and power. insert the paper once the unit has started up.

9.7 Testing after an error has been cleared

Once an error has been cleared, ensure the device is tested by inserting bills and paying out notes/tickets where applicable. A recommended test is 10 notes in and 10 notes/tickets out, this will help limit the number of repeat calls for the same issue.



10 COMPLIANCES AND APPROVALS

10.1 EC Declaration of Conformity

The NV200 Spectral is fully compliant with the Declaration of Conformity (CE Marking) and RoHS.

It is currently undergoing testing for UL approval; this manual will be updated when certification is passed.

10.2 FCC Approval

This equipment has been tested and found to comply with the limits for a Class B digital device, pursuant to part 15 of the FCC Rules. These limits are designed to provide reasonable protection against harmful interference in a residential installation. This equipment generates, uses and can radiate radio frequency energy and, if not installed and used in accordance with the instructions, may cause harmful interference to radio communications. However, there is no guarantee that interference will not occur in a particular installation. If this equipment does cause harmful interference to radio or television reception, which can be determined by turning the equipment off and on, the user is encouraged to try to correct the interference by one or more of the following measures:

- Reorient or relocate the receiving antenna.
- Increase the separation between the equipment and receiver.
- Connect the equipment into an outlet on a circuit different from that to which the receiver is connected.
- Consult the dealer or an experienced radio/TV technician for help.

10.3 Central Bank Approvals

As part of continual product improvement central banks are regularly visited to gain product certification.

The NV200 Spectral has received independent validation from the European Central Bank (ECB), Bank of England (BoE) and the Central Bank of Russia (CBR).

For more information visit our website linked below. This page has further links to the banks' individual websites where the results are published:

<http://www.innovative-technology.com/news-events/news/item/477-nv200-spectral-receives-independent-bank-test-approvals>

Any change in approval status is outlined in our tech bulletins a link to which can be found below:

<http://innovative-technology.com/support/technical-bulletins>



User Manual – NV200 Spectral

[<< Back to Contents](#)

11 APPENDIX

11.1 Cable Drawings

NOTE: If required, IGES 3D models are available on request from ITL technical support.

All parts can be purchased as part of the ITL development kit, details of which can be found on our [website](#).

11.1.1 CN00214

DRAWING NO.		SCALE	
CN00214		1	

Parts List

Item	QTY	Description	Vendor
A	1	USB Type A Male Connector	-
B	1	USB Shielded High Speed 2.0 Cable 28AWG/1P+28AWG/2	-
C	1	USB Type B Male Connector	-

Comments

Note to Manufacturers
 Certifications are needed for the following:
 ■ RoHS compliance ■ UL94-V0 rated (connector housing) ■ UL1581-VW1 rated (all other parts)

REVISIONS		DATE		REVISIONS		DATE	
A	1	15/03/2013	1	15/03/2013	1	15/03/2013	1
B	1	15/03/2013	1	15/03/2013	1	15/03/2013	1

All dimensions are in mm ±0.1mm, unless specified



User Manual – NV200 Spectral

[<< Back to Contents](#)

11.1.2 CN00292

DRAWING NO.	CN292	ISSUE	4
--------------------	--------------	--------------	----------

Terminal

CON1
CON2

Housing

Leotronics 2652-2161 (2x8way 2.54mm pitch with key)
Leotronics 2652-2161 (2x8way 2.54mm pitch with key)

Crimp

2653-2000 (tin plated)
2653-2000 (tin plated)

**Accepted alternatives: 90119-0110 (Molex crimps) and 90142-0016 (Molex housing)*

Connectivity by conductor

CON1 Pin	CON2 Pin	Gauge (AWG)	Colour	Comments
1	1	24	Orange	-
5	5	24	Brown	-
15	15	24	Red	VIN
16	16	24	Black	GND

Note:
Pins 3,4,7,8,9,10,13 and 14 are unloaded
Pins 2,6,11 and 12 are loaded but not connected

ISSUE NO.	CONV. NO.	DATE	APP. BY	DATE	APP. BY	DATE	APP. BY	DATE	APP. BY	DATE	APP. BY	DATE	APP. BY
4	-	27/08/09	A Lunsong	-	-	-	-	-	-	-	-	-	-

<p>All parts must be rated to at least UL94V-0 All connector housings must be rated to UL94V-0</p> <p style="text-align: center;">NOT TO SCALE All dimensions in mm ±2mm</p>	<p style="text-align: center;">2009 Copyright of Innovative Technology Ltd</p> <p style="text-align: center;">IF10 - SSP to Binary Interface Cable</p> <p style="text-align: center;">DRAWN BY: A Lunsong DATE: 27/08/09</p>
---	---



User Manual – NV200 Spectral

[<< Back to Contents](#)

11.1.3 CN00414

DRAWING NO. **CN414**
ISSUE **1**

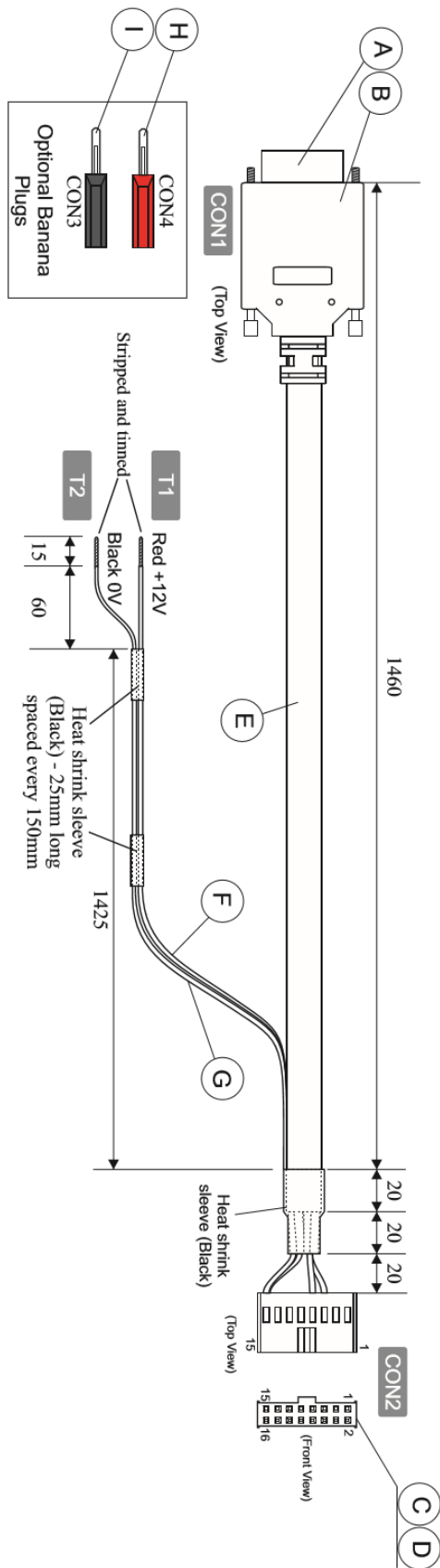

Item	Description
A	MULTICOMP - 5501-09SA-02-F1, SOCKET, D, SOLDER, 9WAY (Farnell 1084678)
B	MH CONNECTORS DPPK9-BLACK-K, D-Sub Shell Plastic 9 Way (Farnell 469-889)
C	MOLEX 9733272, Crimp (tin plated)
D	MOLEX 90142-0016, (2x8way 2.54mm pitch with key)
E	Use 3 or 4 core AWM Style 2464 24AWG Cable, as available (Cut away any unused wires).
F	Red Cable rated to UL1007
G	Black Cable rated to UL1007
H	DELTRON 553-0500-01, Stackable Red 4mm banana plug (Optional).
I	DELTRON 553-0100-01, Stackable Black 4mm banana plug (Optional).

Connectivity by conductor

CON1 Pin	CON2 Pin	CON3 Pin	CON4 Pin	Gauge (AWG)	Colour	Comments
2	6	-	-	24	Brown	RX(DTE-DCE)
5	16	-	-	24	Black	GND
3	7	-	-	24	Orange	TX(DTE-DCE)
-	16	1	-	22	Black	GND
-	15	-	1	22	Red	12V

Note:

All other pins are unloaded.
CON2.16 loaded with two wires in one crimp.

- Comments**
- CON1 Connects with Host
- CON2 Connects to Validator
- T1 Connects to 12V Power Supply
- T2 Connects to 0V(GND) of Power Supply

ISSUE NO.	MOD NO.	DATE	MOD BY	DATE	MOD BY	ISSUE NO.	MOD NO.	DATE	MOD BY	DATE	MOD BY	DATE	MOD BY	DATE	MOD BY	DATE	MOD BY	DATE	MOD BY	
1	-	04/03/2010	P.Newton	-	-	-	-	-	-	-	-	-	-	-	-	-	-	-	-	-

All parts must be rated to at least UL94-VW1
All connector housings must be rated to UL94-V0

INNOVATIVE TECHNOLOGY LIMITED
 GENERAL SALES
 UNIT 10, GLENDALE INDUSTRIAL ESTATE
 TEL: +44(0)1875 820000
 FAX: +44(0)1875 820000

3/4 ANGLE PROJECTION

2009 Copyright of Innovative Technology Ltd
NOT TO SCALE
 All dimensions in mm ±0.3mm

TITLE	DRAWN BY	DATE	CHECKED BY	DATE	MATERIAL	FINISH
RS232 to Validator Cable Assembly	P.Newton	04/03/2010	-	-	-	-



User Manual – NV200 Spectral

[<< Back to Contents](#)

11.1.4 CN00487

COMMUNICATIONS
CN487
SCALE
1

Parts List

Item	QTY	Description	Vendor	Connectivity	CHOKER1	CHOKER2	CON2	CON3	CON4	Gauge	Colour	Comment
A	1	38-01-2165 housing (2x8way/4.2mm pitch Mini-Fit Jr receptacle)	Molex	Pin	B1	-	-	1	22	22	Black	GND
B	6	003900209 (tin plated, female, brass) crimps (4A @ 22AWG, 2A@26AWG)	Molex	Pin	B2	-	-	1	26	22	Black	GND
C	2	30mm black heat shrink sleeve (big diameter to fit over IN02012)	-	Pin	A1	-	-	-	22	22	Red	V_IN
D	2	CM choke (TTL P/N IN02012)	-	Pin	A2	-	-	-	22	22	Blue	SSP_RXD (Host to Validator)
E	8	Black heat shrink sleeve (small diameter to fit)	-	Pin	C1	-	-	-	26	26	Blue	SSP_RXD (Host to Validator)
F	1	Cable tie to secure ferrite sleeve into place	-	Pin	C2	5	-	-	26	26	Blue	SSP_TXD (Validator to Host)
G	1	Ferrite sleeve (2 turns)	See notes	Pin	D1	-	-	-	26	26	White	SSP_TXD (Validator to Host)
H	7	20mm black heat shrink sleeve (spread along the assembly length)	-	Pin	D2	1	-	-	26	26	White	SSP_TXD (Validator to Host)
J	7	Standard AWG 26 wire	-	Pin	-	-	-	-	26	26	White	Pins 16 and 7 are linked together
K	4	Standard AWG 22 wire	-	Pin	-	-	-	-	26	26	Blue	Pins 14 and 5 are linked together
L	1	90142-0016 housing (2x8way 2.54mm pitch receptacle)	Molex	Pin	-	-	-	-	26	26	Blue	
M	3	90119-0120 (tin plated) crimps	Molex	Pin	-	-	-	-	26	26	Black	
N	1	Stackable red 4mm banana plug (553-0500-01)	Deltron	Pin	-	-	-	-	26	26	Black	
P	1	Stackable black 4mm banana plug (553-0100-01)	Deltron	Pin	-	-	-	-	26	26	Black	

Notes
 Ferrite sleeve needs to have >572Ω @ 100MHz.
 Recommended parts:
 a) Wurth 74270060 - 714Ω @ 100MHz (two turns)
 b) Edgar FL8 RH10 x 20 x 6.35 - 724Ω @ 100MHz (two turns)

Notes
 1 turn = threaded through ferrite sleeve
 2 turns = threaded through with one loop

Comments
 CON1 connects to Smart Ticket
 CON2 connects to Host
 CON3 connects to V+ (24V)
 CON4 connects to V- (GND)

Note to Manufacturers
 Certificates are needed for the following:
 ■ RoHS compliance ■ UL94-V0 rated (connector housing) ■ UL94-VW1 rated (all other parts)

Smart Ticket to Host assembly (customer)

STANDARD	DATE	MATERIAL	ISSUE NO.	MOD NO.	DATE	MOD BY
ALunsong	31/01/2012	All parts must be tested to meet UL94-VW1. All connectors must be tested to meet UL94-V0. Material must be RoHS compliant.	1	-	23/08/2013	ALUNSONG

Checklist

ITEM	DESCRIPTION	STATUS
A	IMPRESSIVE TECHNOLOGY CORP	NOT TO SCALE
B	IMPRESSIVE TECHNOLOGY CORP	NOT TO SCALE
C	IMPRESSIVE TECHNOLOGY CORP	NOT TO SCALE
D	IMPRESSIVE TECHNOLOGY CORP	NOT TO SCALE
E	IMPRESSIVE TECHNOLOGY CORP	NOT TO SCALE
F	IMPRESSIVE TECHNOLOGY CORP	NOT TO SCALE
G	IMPRESSIVE TECHNOLOGY CORP	NOT TO SCALE
H	IMPRESSIVE TECHNOLOGY CORP	NOT TO SCALE
I	IMPRESSIVE TECHNOLOGY CORP	NOT TO SCALE
J	IMPRESSIVE TECHNOLOGY CORP	NOT TO SCALE
K	IMPRESSIVE TECHNOLOGY CORP	NOT TO SCALE
L	IMPRESSIVE TECHNOLOGY CORP	NOT TO SCALE
M	IMPRESSIVE TECHNOLOGY CORP	NOT TO SCALE
N	IMPRESSIVE TECHNOLOGY CORP	NOT TO SCALE
O	IMPRESSIVE TECHNOLOGY CORP	NOT TO SCALE
P	IMPRESSIVE TECHNOLOGY CORP	NOT TO SCALE

Dimensions: All dimensions are in mm ±0.5mm, unless specified.



[<< Back to Contents](#)

11.2 Lock Specification

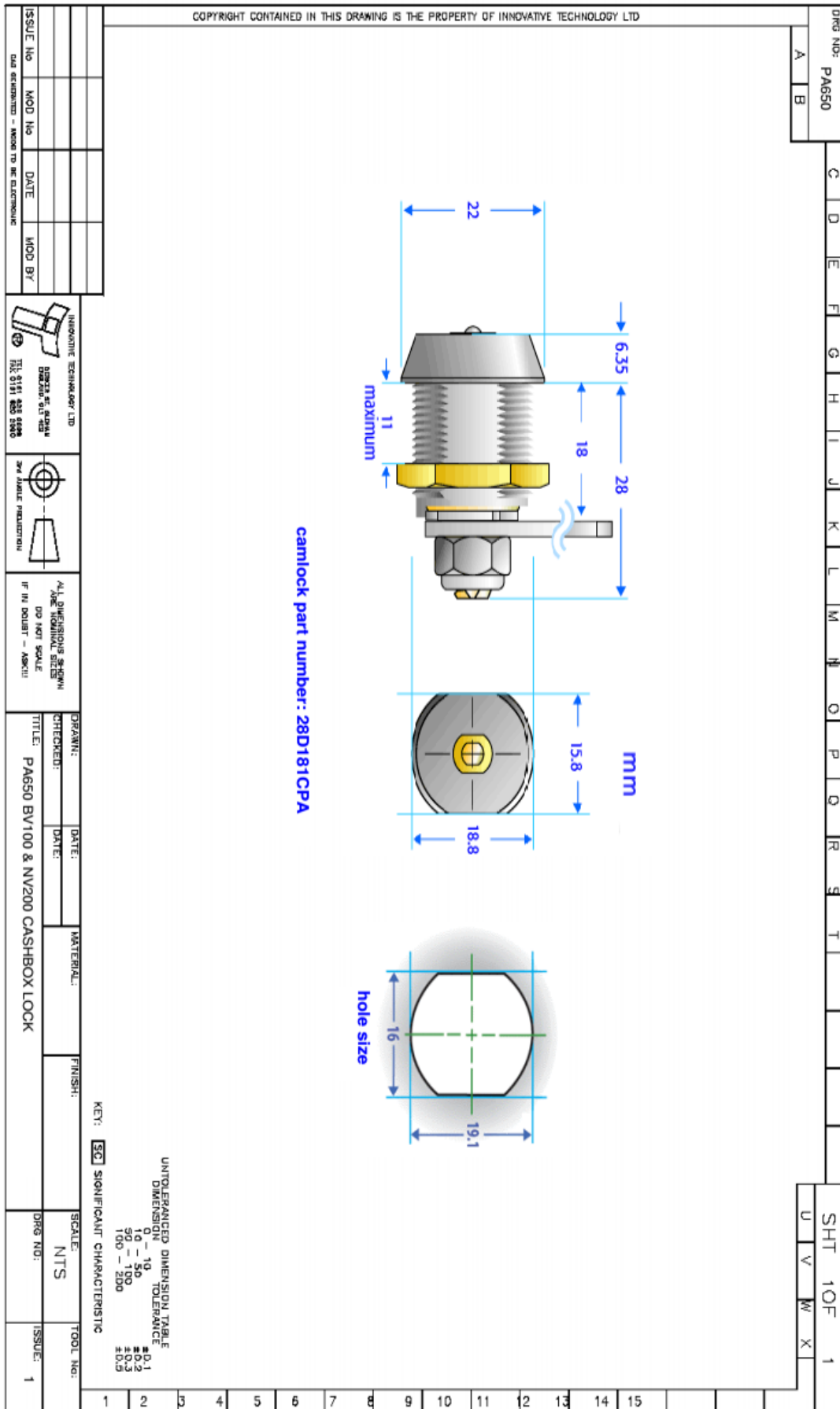

11.2.1 Keyless Locking Cam

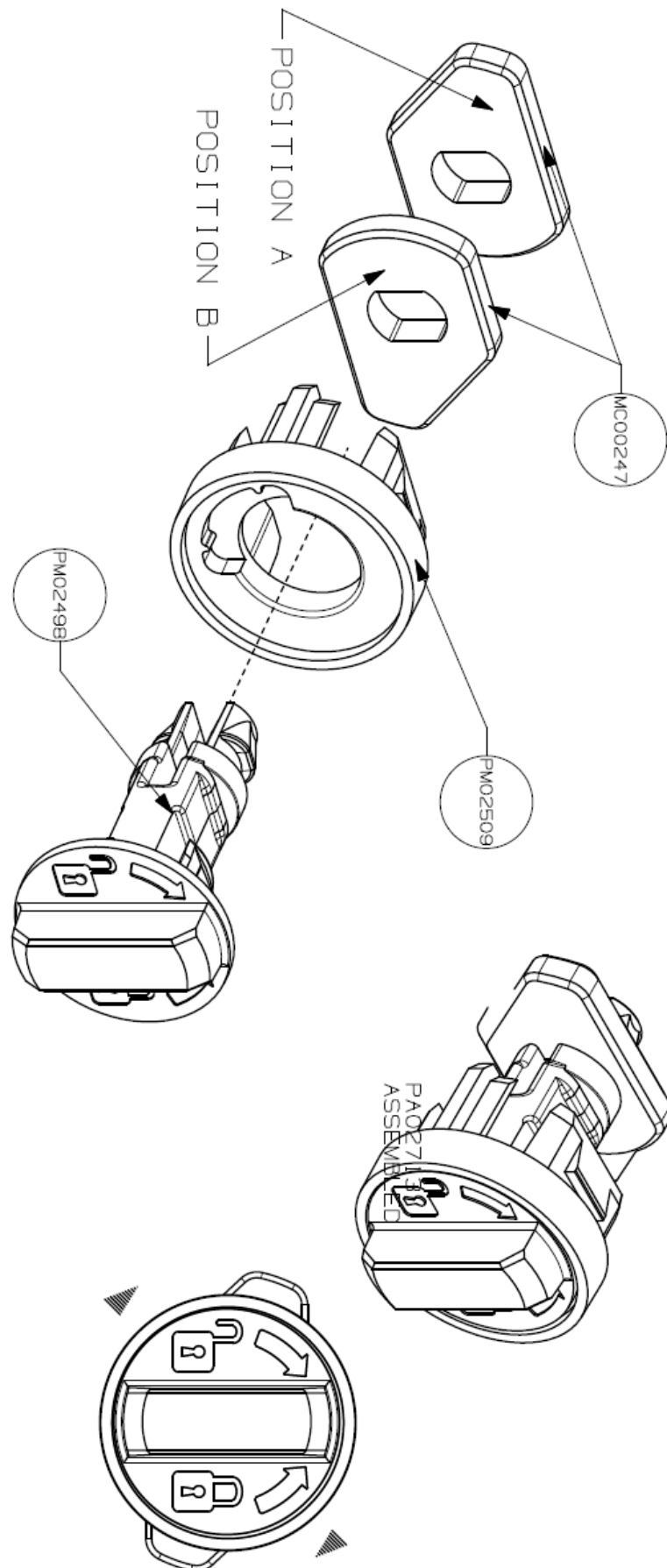

User Manual – NV200 Spectral

[<< Back to Contents](#)

11.2.2 TEBS Locking Cam

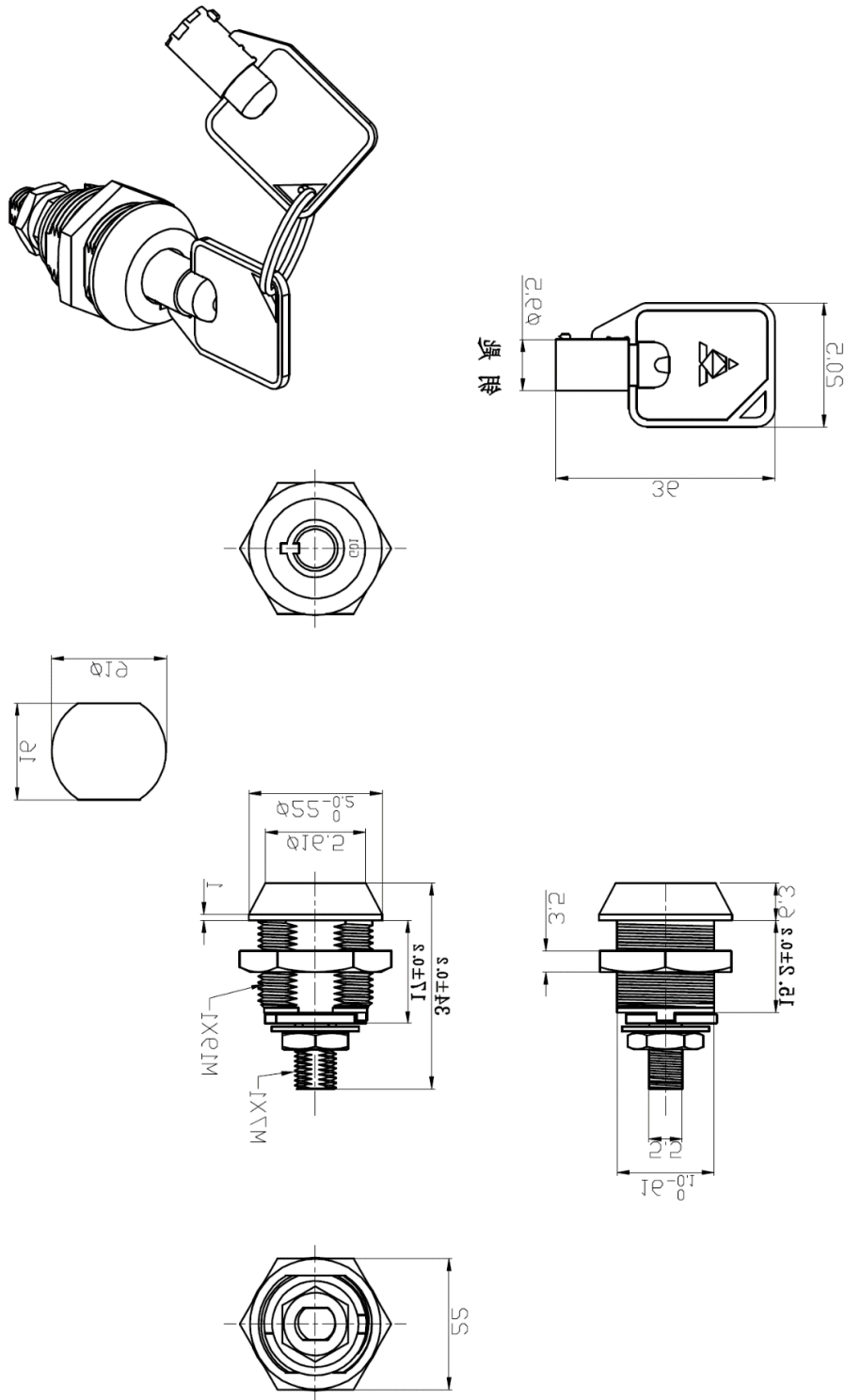

11.3 Connector Specifications

Type	Vendor	Part Number	Pins	Pitch	Polarising
Housing	Leotronics	2652-2161	2x8	2.54mm	With Key
Crimp	Leotronics	2653-2000			Female
Housing	Molex	90142-0016	2x8	2.54mm	With Key
Crimp	Molex	90119-2121			Female

11.4 Switching to Programming Mode (SSP)

If fitted remove the Payout or Ticket modules. Power the NV200 Spectral, once the unit has initialised toggle **dip-switch 8** up and down.

To switch the unit back repeat the procedure explained above.

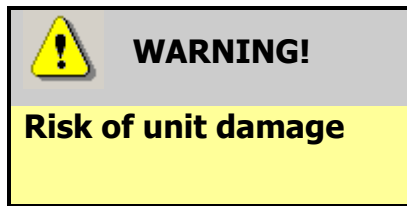

When in programming mode and performing an update, do not turn off the power before the operation is complete as this could make the unit unusable.

11.5 Free Fall Cashbox Advice

The NV200 Spectral cashbox and TEBS cash bag has been designed to remain intact after an impact of 75cm onto a concrete floor. Dropping the cashbox multiple times can result in physical damage to the cashbox/bag.

11.6 ccTalk DES Encryption – Trusted Mode

Ensure the NV200 Spectral has been configured to use DES encryption in Validator Manager, this setting can be found on the options tab. To pair the NV200 Spectral with a DES trusted machine follow the steps below:

1. Remove power from the unit then remove the cashbox
2. Re-power the unit, once the unit has started it should be in pairing mode.

If a Smart Payout module is connected the unit must be empty before it can pair to the host.

11.7 Escrow

The NV200 Spectral has a single note escrow facility. This allows the NV200 Spectral to hold onto the note once validated, and only stack the note into a cashbox when the host machine confirms that the Vend operation has been completed. If no confirmation of the Vend is received, the note will be returned to the user after 30 seconds.

If the host machine itself aborts the transaction by sending the reject command (0x08). Similar commands can be sent depending on the protocol used. For information relating to other protocols contact support.



11.8 Escrow Control

The NV200 Spectral has a single note escrow facility. This allows the NV200 Spectral to hold onto the note once validated, and then only stack the note into a cashbox when the host machine confirms that the vend operation has been completed. The sequence of operation is as follows:

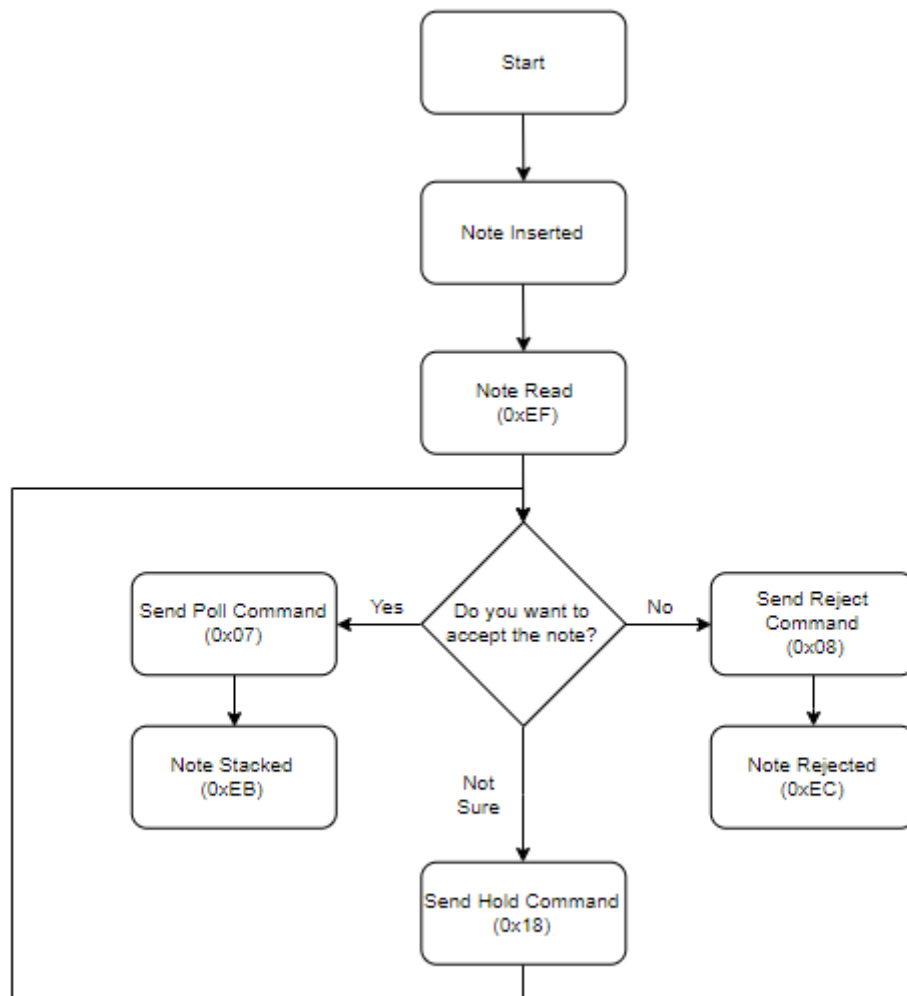

11.9 File Naming Convention

GBP07031_NVS2004132419000_IF_01.bv1



Dataset Code

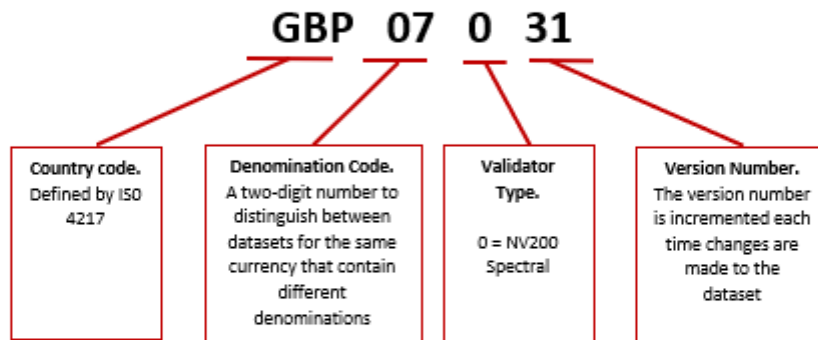

Firmware Code

