

## SMART Payout

- Innovative Technology have developed the SMART Payout to bring advanced multiple-note payout technology to any machine that needs to payout notes.
- The SMART Payout will set the standard for multiple note denomination payout.
- SMART Payout is a modular option for the NV200 bank note validator.
- Multiple denomination note payouts.
- Solution to coin starvation.

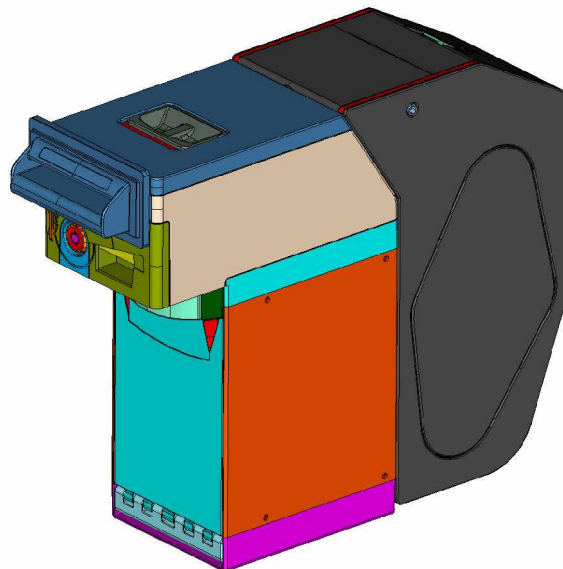

- Multi denominations
- Speed
- Note capacity
- The SMART Payout can accept and later dispense multiple denominations. Capable of accepting up to 100 notes the SMART Payout unit is able to payout the same 100 notes of mixed denominations.
- Self-regulating - notes are stored in the NV200's secure cashbox or travel into the SMART Payout unit if needed for future payouts.
- Accepts, validates and stores multiple denominations < 4 seconds
- Payout of multiple denominations in a similar time
- Note capacity - 100 notes



A.u.S. Spielgeräte GesmbH  
Scheydgasse 48 A-1210 Wien  
Tel. +43-1-271 66 00 Fax.+43-1-271 66 00 75  
E-mail: [verkauf@aus.at](mailto:verkauf@aus.at)  
<http://www.aus.at> <http://www.garlando.at>  
Öffnungszeiten: Mo-Do 9-18 und Fr. 9-17 Uhr

## SMART Payout

- Note payout - 100 multi-denomination notes
- The payout works with any data set created by ITL
- NV200 head must be locked into position for the SMART Payout unit to operate.
- NV200 triple lock capability
- SSP encrypted
- Notes are not visible when in the payout and cannot be taken out manually

### Technical Specification

- Dimensions: 145 x 114 x 298 mm
- Weight: 2.5kg
- 12V power supply
- SSP encrypted protocol
- Lifecycle: 1,000,000 notes
- Capacity: 100 notes; payout 100 notes
- Modular add on for NV200 validator

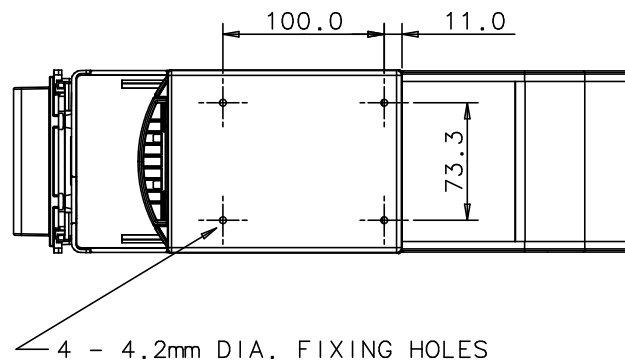
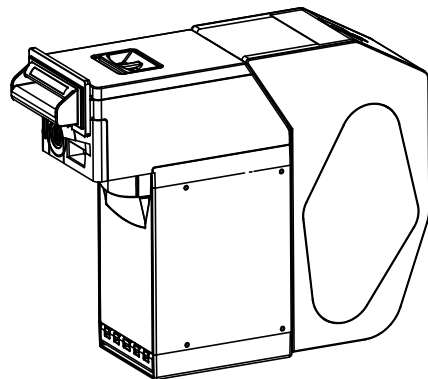
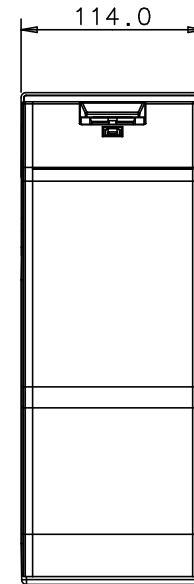
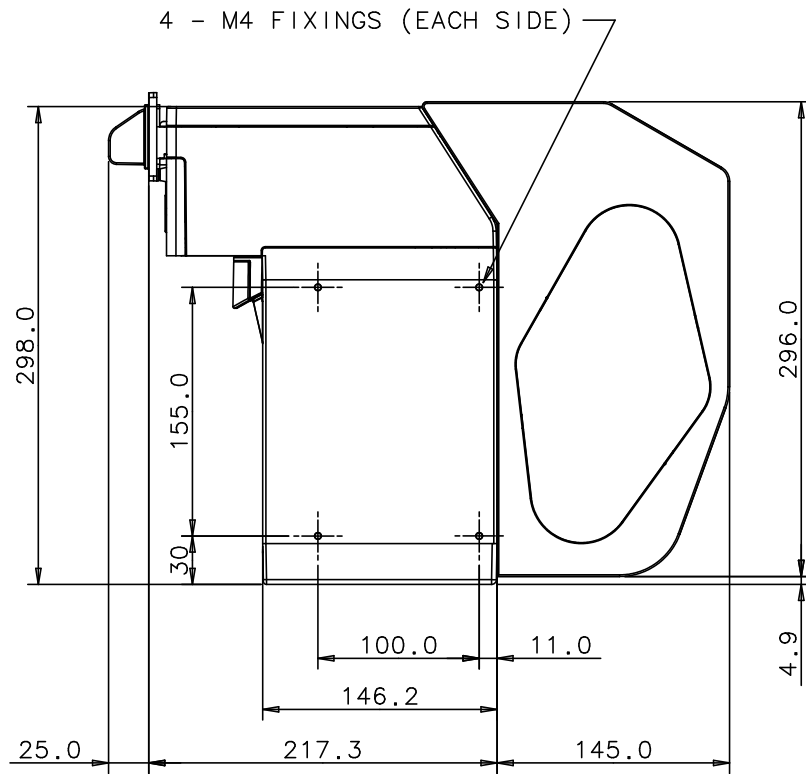
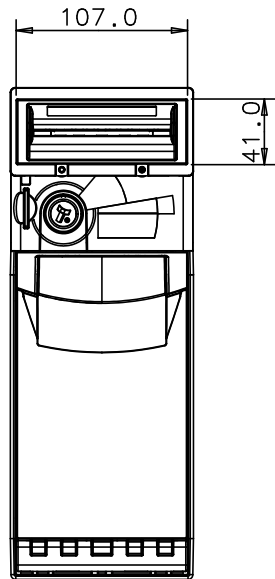

A.u.S. Spielgeräte GesmbH  
 Scheydgasse 48 A-1210 Wien  
 Tel. +43-1-271 66 00 Fax.+43-1-271 66 00 75  
 E-mail: verkauf@aus.at  
 http://www.aus.at http://www.garlando.at  
 Öffnungszeiten: Mo-Do 9-18 und Fr. 9-17 Uhr

PRELIMINARY INFORMATION ONLY.  
 PRODUCT SUBJECT TO CHANGE.

ISSUE No.	MOD No.	DATE	MOD BY

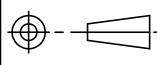
DO NOT SCALE		IF IN DOUBT - ASK !!!		DRAWN	DATE	SCALE	MATERIAL	FINISH	TOOL No.
 INNOVATIVE TECHNOLOGY LIMITED DERKER ST., OLDHAM ENGLAND, OL1 4EQ TELEPHONE. 0161 626 9999 FAX. 0161 620 2090		 3rd ANGLE PROJECTION.		TOLERANCES TO BS7010 (1988) GROUP UNLESS OTHERWISE STATED. ANGULAR TOLERANCE ±0.5°		CHECKED	DATE		
TITLE: NV200 & SMART PAYOUT								DRG No.	ISSUE