



COIN VALIDATOR L66S



1. INTRODUCTION AND DESCRIPTION OF COMPONENTS

The technical information that is presented in this Technical Manual refers to the *coin validators* in the **L66S** range.

The *coin validators* are devices within the machine, and that form part of the machine, that have the function of selecting and validating the coins introduced into the machine. They are used in gambling machines, vending machines, cigarette vending machines, betting machines, etc.

In the rest of this Technical Manual the *coin validators* in the **L66S** range will be called *validator* or *validators*

1.1. TECHNICAL FEATURES

The most relevant technical features and performance are:

- ✚ Voltage and current draw:

	Average	Maximum	Minimum
Voltage	12 Vdc	15 Vdc	10 Vdc
Current draw on validating a coin	50 mA		
Current draw on opening acceptance gate	280 mA		

- ✚ It admits up to 32 different types of coins. Of these 32 coins, 2 can be programmed at the machine on site.
- ✚ It has the option of an effective string detection system which will stop any attempt of fraud using the procedure of tying a string or thread to the coin with the intention of retrieving the coin.
- ✚ The useful life of this equipment is guaranteed for more than 1,000,000 coins.
- ✚ It has a system that generates a "coin return code" when the validator is opened. When this code is activated, the machine interprets that the user wants to retrieve the money inserted and returns the money.

1.2. DESCRIPTION OF COMPONENTS

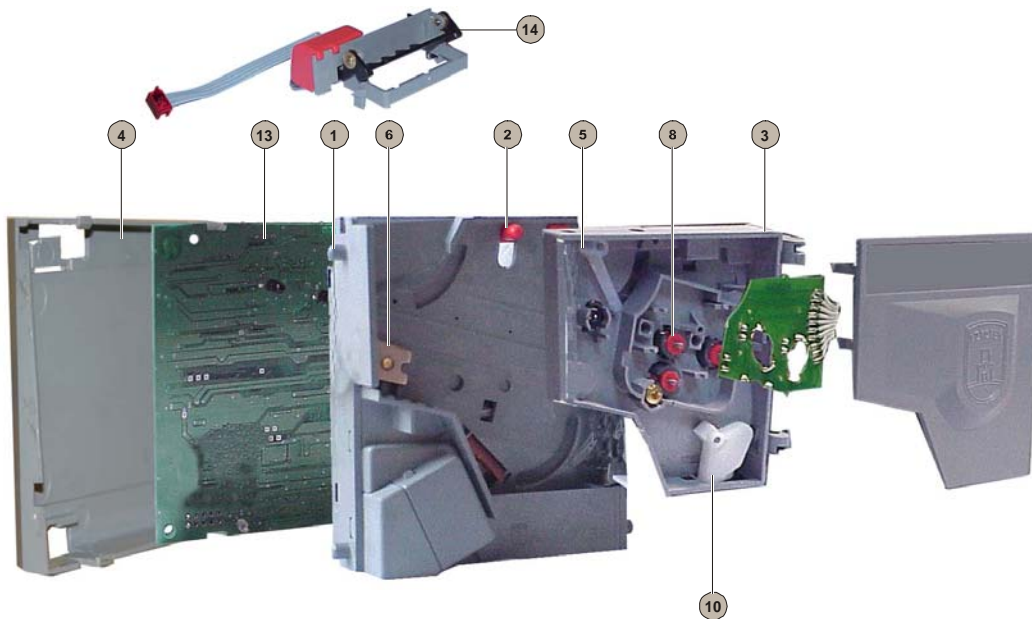

1. Anchorage pivots

Fixing points of the *validator* to the interior of the machine, the \varnothing is 4.5 mm and the length is 5 mm.

2. Coin return lever

Pressing this part will open the *Validator door*, which will eliminate possible coin jams inside the *validator*.

3. Validator door

This is the moving part of the *validator*. When the coin return lever is pressed, it opens.

4. Circuit board cover

It is designed to protect the printed circuit board on the *validator*.

5. Rocker

This element catches the coin and slows it down so that all coins pass through the *validator* at the same speed, which makes all measurements more accurate.

6. Metal ramp

This is hit by the coin to produce a sound collected by the *acoustic sensor*.

7. Acoustic sensor

It picks up the sound the coin makes on hitting the *metal ramp*. The parameters taken by

this sensor are very important in the validation process of the coin.

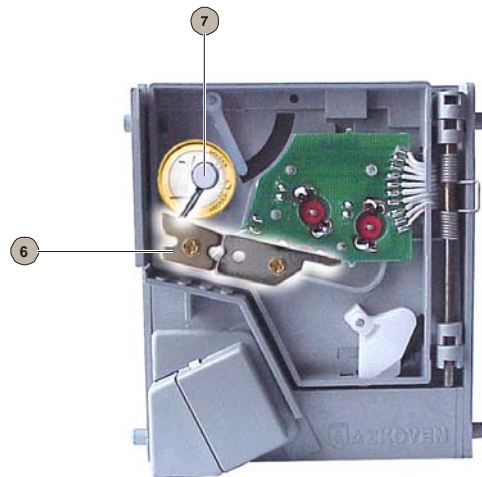

8. Inductive sensors

3 pairs of sensors obtain coin parameters related to their alloy and thickness. Their layout improves the reading of coins made using bi-metallic or multi-layer technology. Examples of these are the €1 and €2 coins.

9. Infrared sensors

They obtain coin parameters related to their diameter.

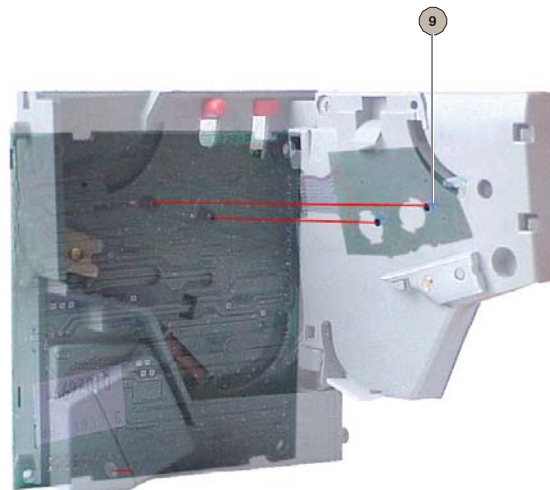

10. Outlet rocker

This directs the coins introduced into the *validator* and stabilises the speed of the rejected coins.

11. Outlet sensor

Placed below the coin accepted exit, this is the last check the validator does to verify the

coin has completed its cycle through the *validator* correctly.

12. Acceptance gate

When the *validator* validates a coin, an electromagnet pulls the gate open letting the coin pass through the acceptance channel.

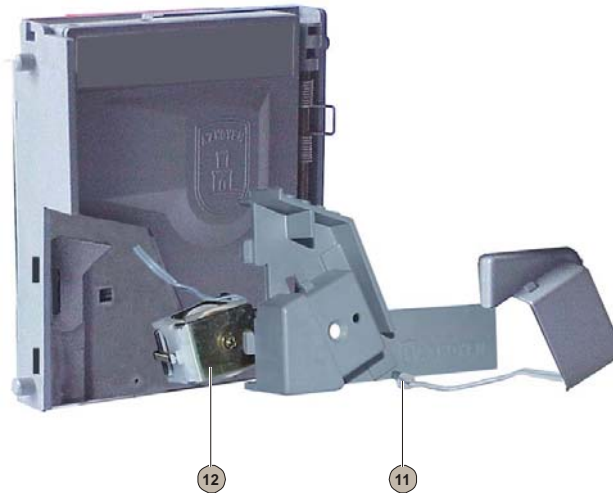

13. Circuit board

The principle elements are:

- EEPROM 25C320 4Kbyte Memory.
- **A.** 9 Mhz Quartz crystal.
- **B.** Microprocessor. It has an analogical/digital converter, an EPROM memory to store the programme. It has a capacity of 8Kx14 and a RAM memory of 368 Bytes for data management.
- **C.** Four dipswitches that are used to inhibit certain coins and to auto programme the *validator*.
- **D.** J5: A 3-pin communication connector used in the auto-programming process of the *validator*.
- **E.** J6: A 4-pin connector for connecting "string detector" to the *validator*. The L66S range is capable of detecting the presence of the string detection system.
- **F.** J3: A 10-pin connector for data input/output and power. It is for connecting the *validator* to the machine. A Molex 10-way serial connector 5320, reference 39-51-2100.

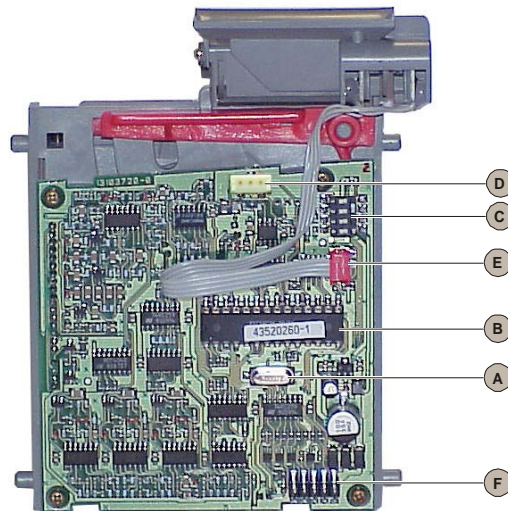

14. String detector

The electro-mechanical system detects any fraud attempt using the coin tied to a string method. It work by using an infrared beam that passes through a hole in the rocker placed over the coin entry. When the string tenses, it moves the rocker breaking the infrared beam which the *Coin validator* interprets as a fraud attempt and does not validate the coin. The fraud signal is maintained while the beam is interrupted.

The *Coin validator* analyses the string detector status every 100 milliseconds.

2. OPERATING PRINCIPLES

2.1. How it works

An important characteristic of the **L66S** range is that it communicates with the machine allowing it to make decisions on admission and rejection of coins and the destination of them. Communication between the two is described below:

FIGURE 1: A valid coin has been detected

FIGURE 2: A coin has been accepted

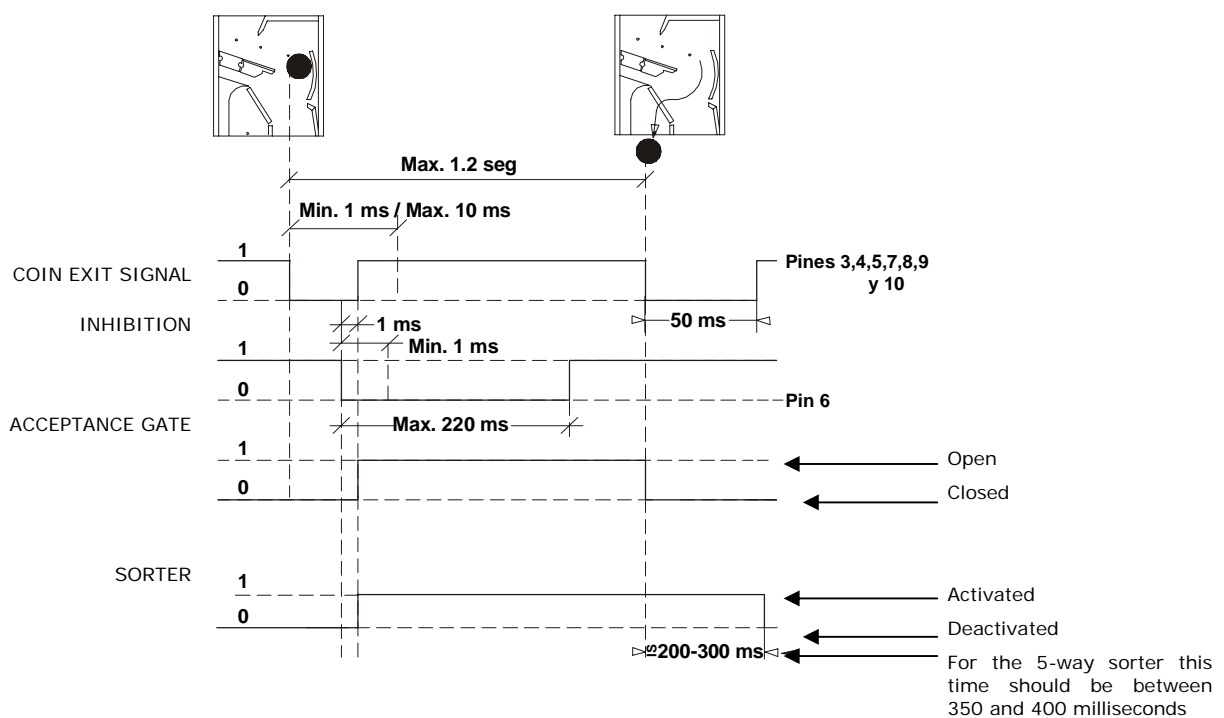

FIGURE 1 shows the instant at which the coin has passed all the sensors that are used for its analysis and the *validator* begins communication with the machine.

The communication cycle consists of transmission, for 10 milliseconds, of the code of the coin identified so the machine can decide on its admission or rejection and instruct the *sorter* to direct the coin where it wants. For the coin to be admitted, the machine should put the inhibition line (pin 6) low (0 volts) before the 10-millisecond transmission of the coin code is finished. If this does not happen, the validator will reject the coin. If the machine puts the inhibition line low while the validator is transmitting, it will cease transmission and open the acceptance gate so the coin is accepted. At this moment the machine can now instruct, if necessary, the *sorter* to act.

In FIGURE 2 can see how the coin breaks the photocell beam as it leaves the *validator*. When

this beam is again visible, the *validator* determines that the acceptance cycle has concluded, therefore, it deactivates (closes) the acceptance gate and transmits the coin code for 50 milliseconds so the machine can account it. The *sorter* remains active for 200 to 300 milliseconds after the *validator* detects the exit of the coin to ensure that it leaves correctly. If a 5-way sorter is used, this time should be extended to 350 to 400 milliseconds.

2.2. Programming 2 coins or metallic tokens

The auto-programming method to follow for the two coins or tokens is described below:

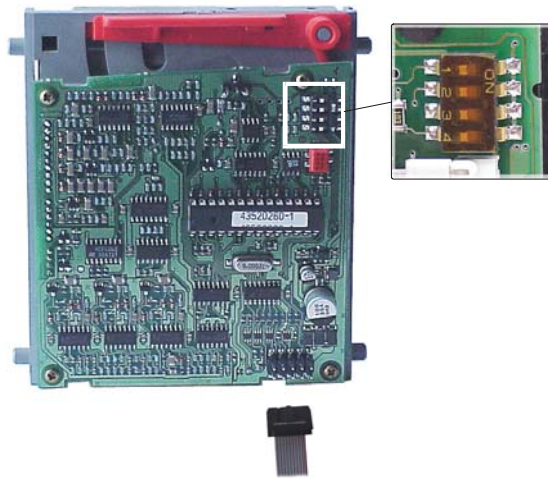

1. Disconnect the loom from J3 on the *validator*.
2. Remove the validator cover and put dipswitch 1 ON or OFF to determine which coin or token is to be programmed.
Dipswitch 1 in position OFF: Programme token 1
Dipswitch 1 in position ON: Programme token 2

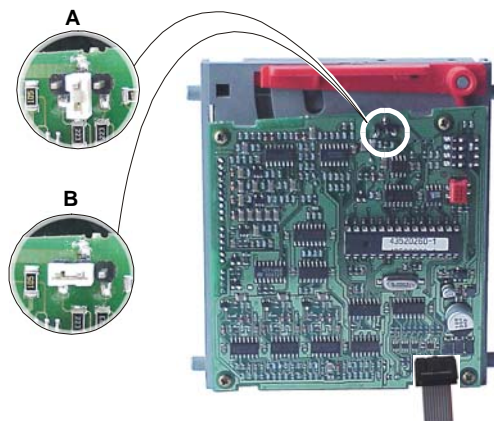

3. Reconnect the loom to J3 on the *validator*. Short the left and centre pins on J5. The acceptance gate solenoid in the *validator* makes a short “click”; this signal indicated that the *validator* is ready to be programmed.



4. Insert a minimum of 25 coins or tokens to be programmed into the *validator*. If these coins or tokens are within the acceptance parameters of the *validator*, they will be accepted and leave through the coin accepted channel.

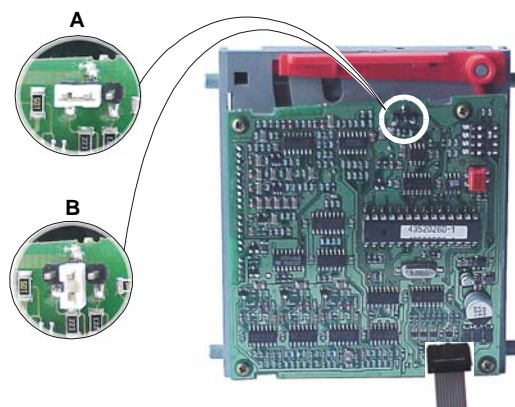

5. Now remove the short on the left and central pin of J5. On doing this, the solenoid in the validator should make a short “click”; this signal indicates that the *validator* is programmed for the new coins or tokens. If there has been an anomaly in the programming process, this short click will not be heard.



6. Disconnect the loom from the machine to the validator and replace the cover.

To erase the programming of a coin or token, follow the same process **without** inserting any coins or tokens in the *validator* described in step 4.

3. WORKING CONDITIONS AND NORMS

Optimum results from using this equipment can be obtained by meeting the following requirements:

- Install the Coin validator with a maximum inclination of +/- 3° on all axes.
- Temperatures:
 - ↘ Storage: from -25 to +70°C.
 - ↘ Working: from +5 to +55°C.
- Humidity: maximum 95% (relative humidity without condensation)
- Physical characteristics of the coins that, see abaco, are admissible:

	Minimum	Maximum
Diameter	17.5 mm	32 mm
Thickness	1.2 mm	3.3 mm

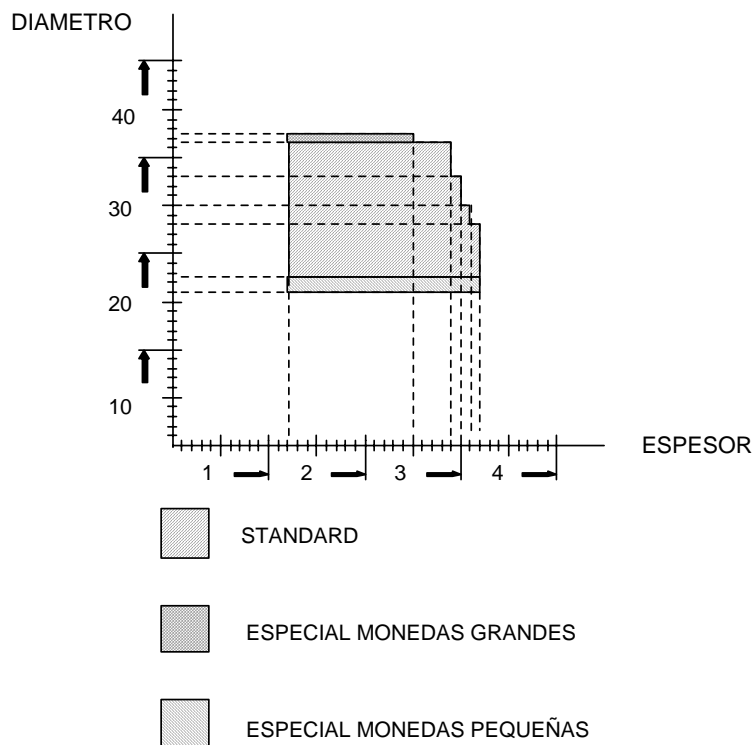



The typical admission rate of legal coins is 96% on the first try (coin without deformations and with standard electrical conductivity and standard magnetic permeability).

☐ Norms that are met:

↳ EN50081-1. General emission norm.

- EN50022: Radiated emission (measurement of the radiated perturbation field).
- EN50022: Conductive emission (measurement of the conductive perturbations in power supply).

↳ EN50082-1: General immunity norm.

- IEC801-2: Electrostatic discharges (measurement of the immunity to electrostatic discharges).
- IEC801-3: Radiation immunity (measurement of the immunity to electric fields).
- IEC801-4: Transitory peaks and spikes (Measurement of the immunity of transitory peaks and spikes).

↳ EN60335-1 (94-95).

↳ CE



4. CLEANING AND MAINTENANCE

The amount of dirt coins leave and the foreign objects and dirt that may obstruct its elements determine the maintenance the coin validator requires. Use the following guidelines for cleaning:

- Disconnect the power.
- Clean the dirty areas with paint brush or brush with fine vegetable fibres (never metal) impregnated with alcohol. Thoroughly clean the coin entry channel, metal ramp and the optic sensor windows.

WARNING:

Internal parts that are held with screws should never be dismantled. Their manipulation may result in alignment problems that provoke errors in measurement.

Never use products that contain benzene hydrocarbons. These products severely degenerate the plastic parts producing irreparable damage.

Never submerge the *Coin validator* in any liquid.

3. DIMENSIONS

Validator

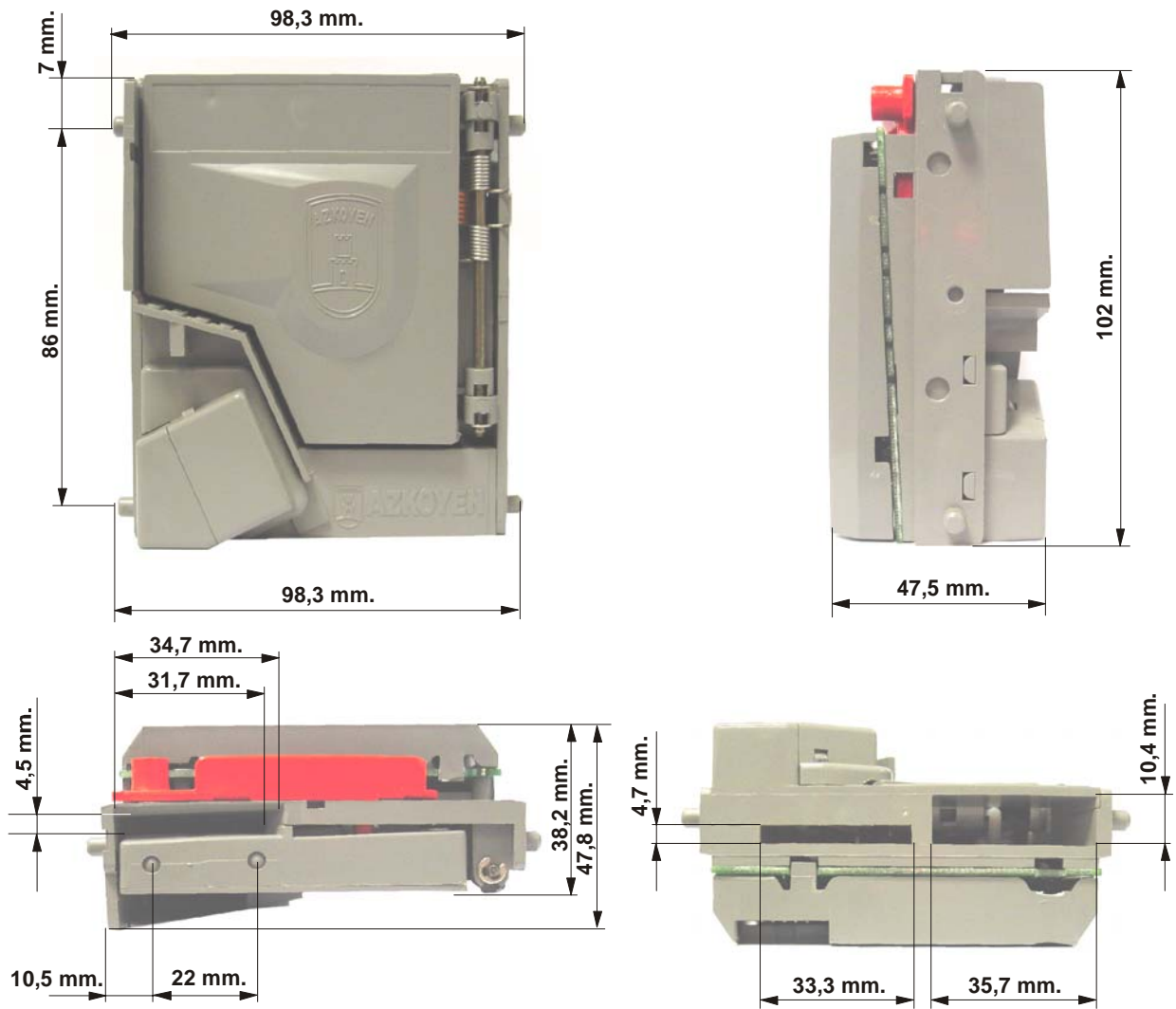

Coin inlets

Coin inlet funnel



Shortened inlet funnel



Short inlet funnel



Medium inlet funnel



String detectors

Long string detector



Long string detector (narrow)



String detector for coin changer



Short string detector



Telephone string detector

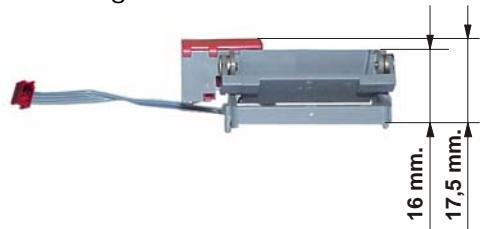

Telephone string detector (narrow)

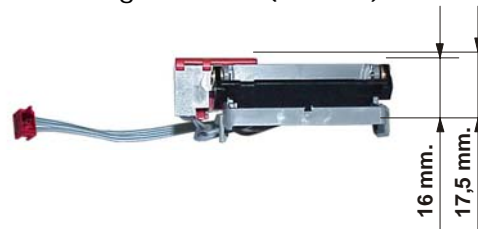

5. PIN OUT

Connector J3, general *validator* connector; J5, programming connector, and J6, string detector connector, are shown below:

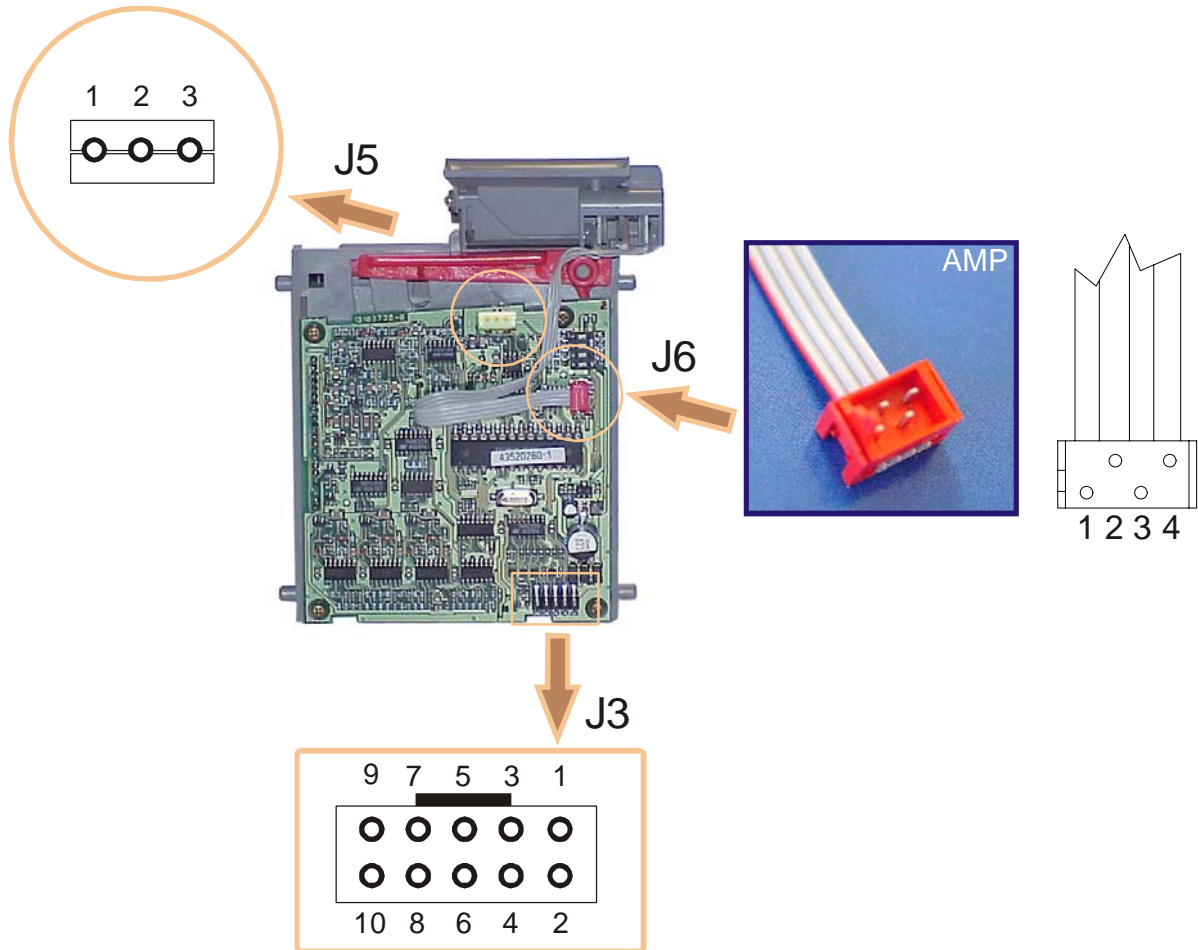

10-WAY CONNECTOR J3	
Pin	Function
1	+ 12 Vdc
2	GND
3	Coin data
4	Coin data
5	Coin data
6	General inhibition
7	Coin data
8	Coin data
9	Coin data
10	Coin data

3-WAY CONNECTOR J5	
Pin	Function
1	RXD
2	GND
3	TXD

STRING DETECTOR CONNECTOR J6	
Pin	Function
1	Phototransistor detector
2	GND
3	Cathode photodiode emitter
4	Anode photodiode emitter



Brands of



AZKOYEN

AZKOYEN MEDIOS DE PAGO S.A.

AZKOYEN

H O S T E L E R Í A

Teidde