

CUBE HOPPER[®] MKII

Instruction - Service Manual

Intelligent Cube Hopper

Model 10-18XX-XX

Version 2.0 / Apr 2013

A new design to solve most of your payout problems!

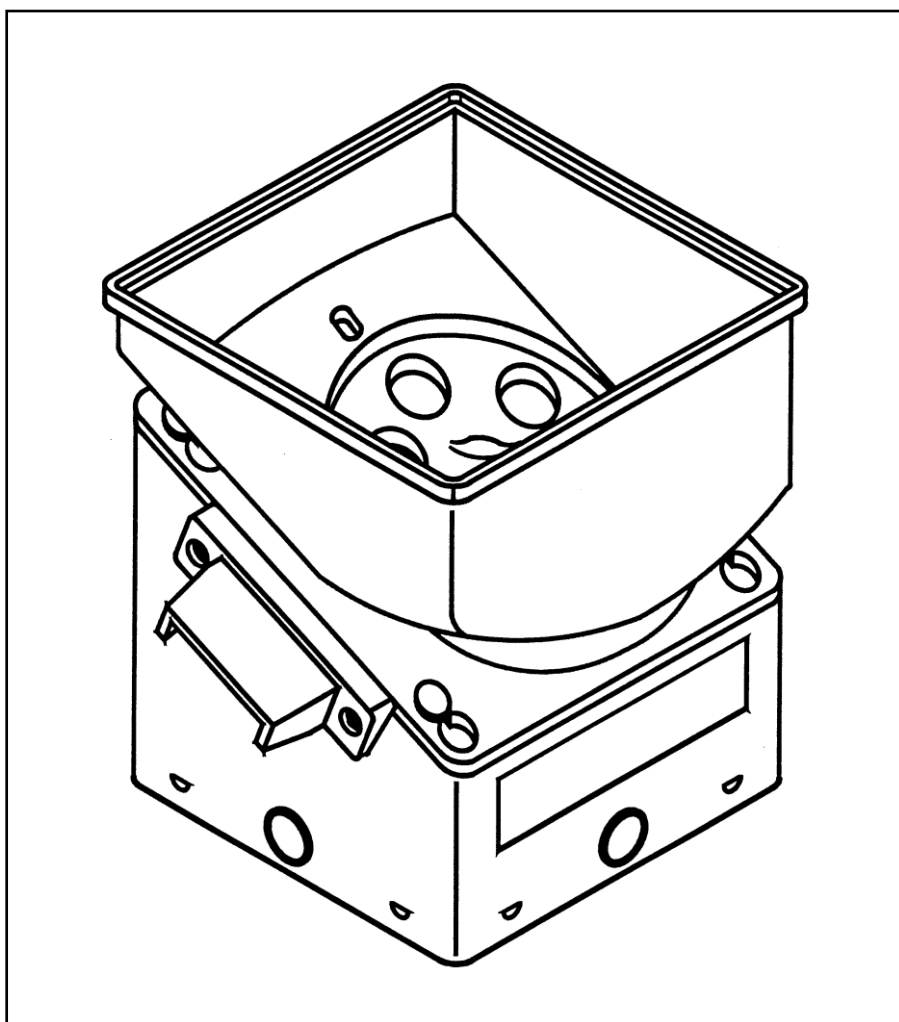

A.u.S. SPIELGERÄTE GMBH

SCHEYDGASSE 48, AT 1210 WIEN

☎ +43 (0) 1 271 66 00 65 FAX +43 (0) 1 271 66 00 75

🌐 www.aus.at ✉ verkauf@aus.at

TABLE OF CONTENTS

REFERENCE CHART	3
Instruction Manual	5
1. Standard hopper for different applications	5
1.1. Features.....	5
1.2. Disassembly	5
Service Manual.....	6
2. Electrical features.....	6
2.1. Connections.....	6
3. Interface signals	7
3.1. Low Level Pins.....	7
3.2. Start input	7
3.3. Mode input	7
3.4. Busy / Ready output	7
3.5. Coin Exit output	7
3.6. VIN	7
3.7. Signal Gnd	7
3.8. Motor control.....	8
3.9. Current consumption	8
3.10. Power supply requirements	8
3.11. Coin counting.....	8
4. Hopper Operation.....	9
4.1. Mode's	9
4.2. Continuous mode	9
4.3. Continuous mode normal operation	9
4.4. Continuous mode anti-jam operation	10
4.5. Logic mode	11
4.6. Logic mode normal operation.....	11
4.7. Logic mode anti-jam operation.....	12
4.8. Pulsed mode.....	13
4.9. Pulsed mode normal operation	13
4.10. Pulsed mode anti-jam operation	13
5. Mechanical features	14
5.1. Dimensions & Weight	14
5.2. Removing the Motor and Gearbox	14
5.3. Coin routing	14
6. Maintenance.....	15
6.1. Removing and re-installing the hopper.....	15
6.2. Cleaning and Materials.....	15
7. Troubleshooting.....	15
7.1. Coins fail to unjam	15
7.2. Motor fails to run.....	15
7.3. Over payout of coins.....	15
7.4. Under payout of coins.....	15
7.5. No payout signal.....	15
8. Optional add-ons	16
8.1. Cup extension (Part No. 10-0200).....	16
8.2. Cube Hopper spillage cover (Part No. 10-0005).....	16

REFERENCE CHART

Model no. 10-18XX-10

Diameter 15.40 to 17.55mm. Thickness 1.30 to 1.70mm.
Disc is marked "1" (Part no. **10-0240-1**).
Use coin insert plate **9** (Part no. **10-0238-9**).
Coin bridge no mark (Part no. **10-0239**).

Model no. 10-18XX-15

Diameter 18.00 to 18.99mm. Thickness 1.50 to 2.09mm.
Disc is marked "2" (Part no. **10-0240-2**).
Use coin insert plate **11** (Part no. **10-0238-11**).
Coin bridge no mark (Part no. **10-0239**).

Model no. 10-18XX-18

Diameter 18.00 to 18.99mm. Thickness 2.10 to 3.20mm.
Disc is marked "3" (Part no. **10-0240-3**).
Use coin insert plate **11** (Part no. **10-0238-11**).
Coin bridge no mark (Part no. **10-0239**).

Model no. 10-18XX-20

Diameter 19.00 to 22.09mm. Thickness 1.50 to 2.09mm.
Disc is marked "2" (Part no. **10-0240-2**).
Use coin insert plate **A** (Part no. **10-0238**).
Coin bridge no mark (Part no. **10-0239**).

Model no. 10-18XX-22

Diameter 19.00 to 22.09mm. Thickness 1.30 to 1.45mm.
Disc is marked "22" (Part no. **10-0240-22**).
Use coin insert plate **A** (Part no. **10-0238**).
Coin bridge no mark (Part no. **10-0239**).

Model no. 10-18XX-30

Diameter 19.00 to 22.09mm. Thickness 2.10 to 3.20mm.
Disc is marked "3" (Part no. **10-0240-3**).
Use coin insert plate **A** (Part no. **10-0238**).
Coin bridge no mark (Part no. **10-0239**).

Model no. 10-18XX-40

Diameter 22.10 to 23.89mm. Thickness 1.50 to 2.09mm.
Disc is marked "4" (Part no. **10-0240-4**).
Use coin insert plate **B1** (Part no. **10-0238-1**).
Coin bridge no mark (Part no. **10-0239**).

Model no. 10-18XX-41

Diameter 23.90 to 25.59mm. Thickness 1.50 to 2.09mm.
Disc is marked "4" (Part no. **10-0240-4**).
Use coin insert plate **B2** (Part no. **10-0238-2**).
Coin bridge no mark (Part no. **10-0239**).

Model no. 10-18XX-44

Diameter 22.10 to 23.89mm. Thickness 1.30 to 1.45mm.
Disc is marked "44" (Part no. **10-0240-44**).
Use coin insert plate **B1** (Part no. **10-0238-1**).
Coin bridge no mark (Part no. **10-0239**).

Model no. 10-18XX-50

Diameter 22.10 to 23.89mm. Thickness 2.10 to 3.20mm.
Disc is marked "5" (Part no. **10-0240-5**).
Use coin insert plate **B1** (Part no. **10-0238-1**).
Coin bridge no mark (Part no. **10-0239**).

Model no. 10-18XX-51

Diameter 23.90 to 25.59mm. Thickness 2.10 to 3.20mm.
Disc is marked "5" (Part no. **10-0240-5**).
Use coin insert plate **B2** (Part no. **10-0238-2**).
Coin bridge no mark (Part no. **10-0239**).

Model no. 10-18XX-80

Diameter 30.10 to 31.00mm. Thickness 1.50 to 2.09mm.
Disc is marked "8" (Part no. **10-0240-8**).
Use coin insert plate **5** (Part no. **10-0238-5**).
Coin bridge no mark (Part no. **10-0239**).

Model no. 10-18XX-83

Diameter 25.60 to 27.89mm. Thickness 1.50 to 2.09mm.
Disc is marked "8" (Part no. **10-0240-8**).
Use coin insert plate **C1** (Part no. **10-0238-3**).
Coin bridge no mark (Part no. **10-0239**).

Model no. 10-18XX-84

Diameter 27.90 to 30.09mm. Thickness 1.50 to 2.09mm.
Disc is marked "8" (Part no. **10-0240-8**).
Coin bridge no mark (Part no. **10-0239**).

Model no. 10-18XX-85

Diameter 30.10 to 31.00mm. Thickness 1.50 to 2.09mm.
Disc is marked "8" (Part no. **10-0240-8**).
Use coin insert plate **5** (Part no. **10-0238-5**).
Coin bridge no mark (Part no. **10-0239**).

Model no. 10-18XX-93

Diameter 25.60 to 27.89mm. Thickness 2.10 to 3.20mm.
Disc is marked "9." (Part no. **10-0240-9**).
Use coin insert plate **C1** (Part no. **10-0238-3**).
Coin bridge no mark (Part no. **10-0239**).

Model no. 10-18XX-94

Diameter 27.90 to 30.09mm. Thickness 2.10 to 3.20mm.
Disc is marked "9." (Part no. **10-0240-9**).
Use coin insert plate **C2** (Part no. **10-0238-4**).
Coin bridge no mark (Part no. **10-0239**).

Model no. 10-18XX-95

Diameter 30.10 to 31.00mm. Thickness 2.10 to 3.20mm.
Disc is marked "9." (Part no. **10-0240-9**).
Use coin insert plate **5** (Part no. **10-0238-5**).
Coin bridge no mark (Part no. **10-0239**).

THE "EURO-HOPPERS"

Model no. 10-18XX-25, "Euro-hopper"

Special hopper for €0.20 coins.
Disc is marked "99". (Part no. **10-0240-99**).
Use coin insert plate **7** (Part no. **10-0238-7**).
Coin bridge marked 10-0239-3 (Part no. **10-0239-3**).
Special Euro Coin Bridge €0.20, €0.50, €1.00 and €2.00 coins.

Model no. 10-18XX-99, "Euro-hopper"

For €0.50, €1.00 and €2.00 coins.
Disc is marked "99". (Part no. **10-0240-99**).
Use coin insert plate **B1** (Part no. **10-0238-1**).
Coin bridge marked 10-0239-3 (Part no. **10-0239-3**).
Special Euro Coin Bridge €0.20, €0.50, €1.00 and €2.00 coins.

THE "SPECIAL-HOPPERS"

Model no. 10-18XX-82 "Special-hopper"

For 50 pence UK coins.
Disc is marked "8" (Part no. **10-0240-8**).
Use coin insert plate **B2** (Part no. **10-0238-2**).
Coin bridge no mark (Part no. **10-0239**).

Model no. 10-18XX-88 "Special-hopper"

For CHF 0.50 coins.
Disc is marked "22" (Part no. **10-0240-22**).
Use coin insert plate **11** (Part no. **10-0238-11**).
Coin bridge no mark (Part no. **10-0239**).

Payout discs

Mark on disc		Diameter*	Thickness*	Part no.
New	Old			
1		15.40 - 17.55	1.30 - 1.70	10-0240-1
2	A	18.00 - 22.09	1.50 - 2.09	10-0240-2
22		18.00 - 22.09	1.30 - 1.45	10-0240-22
3	AA	18.00 - 22.09	2.10 - 3.20	10-0240-3
4	B	22.10 - 25.59	1.50 - 2.09	10-0240-4
44		22.10 - 25.59	1.30 - 1.45	10-0240-44
5	BB	22.10 - 25.59	2.10 - 3.20	10-0240-5
6.	C	25.60 - 30.09	1.50 - 2.09	10-0240-6
7	CC	25.60 - 30.09	2.10 - 3.20	10-0240-7
8		25.60 - 31.00	1.50 - 2.09	10-0240-8
9.		25.60 - 31.00	2.10 - 3.20	10-0240-9
99		€0.20 - €0.50 - €1.= - €2.=		10-0240-99

Coin insert plates

Mark on plate	Diameter*	Part no.
9.	15.40 - 17.55	10-0238-9
11	18.00 - 18.99	10-0238-11
A	19.00 - 22.09	10-0238
B1	22.10 - 23.89	10-0238-1
B2	23.90 - 25.59	10-0238-2
C1	25.60 - 27.89	10-0238-3
C2	27.90 - 30.09	10-0238-4
5	30.10 - 31.00	10-0238-5
7	special €0.20	10-0238-7

*all sizes are in millimetres (mm)

PLEASE NOTE:

Changes have been made to the previously used configuration of the Cube Hopper.

- Payout disc 10-0240-6: replaced by 10-0240-8.
- Payout disc 10-0240-7: replaced by 10-0240-9.
- Hopper 10-1800-60: replaced by 10-1800-83.
- Hopper 10-1800-61: replaced by 10-1800-84.
- Hopper 10-1800-70: replaced by 10-1800-93.
- Hopper 10-1800-71: replaced by 10-1800-94.

Which hopper to use for which Euro-coin:

€0.01	10-1800-10	€0.20	10-1800-25
€0.02	10-1800-15	€0.50	10-1800-99
€0.05	10-1800-20	€1.00	10-1800-99
€0.10	10-1800-20	€2.00	10-1800-99

Congratulations on your purchase of this **INTELLIGENT CUBE HOPPER MKII**
and thank you for having confidence in our **SUZHAPP** quality products

Instruction Manual

1. Standard hopper for different applications

The CUBE HOPPER is a single coin payout system made universal by using the relevant payout disc and coin insert plate (see Reference Chart).

It can be used with all round coins with a diameter between 15.40 and 31.00mm and a thickness ranging from 1.30 to 3.20mm.

1.1. Features

The hopper is square and easy to mount by means of a standard mounting-bracket (included).

By using a unique "sun and planet" gearbox system this hopper offers the possibility to contain and count up to 1,000 coins of €0.50 (if fitted with two cup-extensions).

The hopper is protected by an auto-reverse anti-jam system and has an indirect optical readout.

A low level sensing detection is integrated into the coin cup and can be connected to pin 1 and 2 of the connector.

When using the correct pin on the connector, the hopper operates on a low safe voltage (12VDC or 24VDC).

PLEASE NOTE:

This unit was not designed to be used solely as a coin counter. Before starting a payout, there should already be coins present in the coin cup. These coins should be at rest before payout occurs. The motor should only be active while a payout is in progress.

1.2. Disassembly

How to remove the disc

- a) Slide the yellow button on the back to "down" position.
- b) Remove the coin cup by sliding it upwards and lift the cup from the platform.
- c) You are now able to remove the disc from the platform.

How to remove the coin insert plate

- a) Remove the cup and disc from the platform as described above.
- b) Remove the outlet bridge by pulling it up firmly.
- c) Gently lift up the coin insert plate using a small screwdriver.

How to re-configure the Cube Hopper

- a) Remove the coin cup.
- b) Remove the disc and/or coin insert plate (if necessary) and replace them with the ones necessary to achieve the desired configuration.
Before placing the new disc onto the platform:
 - I) Please check that the correct coin insert plate is mounted on the platform under the bridge. (See Reference Chart)
 - II) Don't forget to put the black Teflon bearing in the centre of the platform. Make sure that the metal ring in the disc is present as well.
- c) Bring the coin cup onto the platform and slide the yellow button to the up position to lock it in place.

NOTE: Please look up the correct configuration for your hopper in the Reference Chart.

Service Manual

2. Electrical features

2.1. Connections

Pin 1	low level
Pin 2	low level (common).
Pin 3	start input.
Pin 4	mode input.
Pin 5	Busy / Ready output
Pin 6	Coin Exit output
Pin 7	Power Supply (12 or 24VDC).
Pin 8	Signal common ground.
Pin 9	Power ground (0V).

You can use a 9-pin Molex connector (Part no. 22-01-2095) and crimp terminals (Part no. 08-50-0032) or equivalent with a pitch of 0.1" (2.54mm).

Be careful with the pin numbering of the connector, because not all manufacturers start numbering from the same pin.

Furthermore, all assemblies are connected to the main PCB with JST connectors.

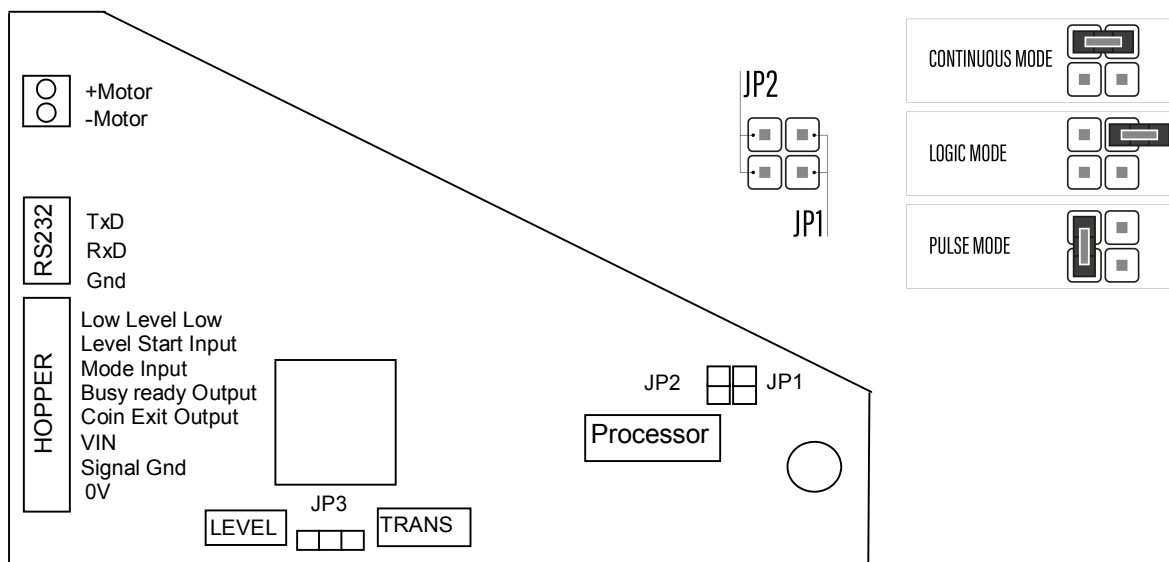

Figure 1: Hopper Control Board

- The RS232 connector can be used to perform serial communication with the processor on the board. IC 6 (Max202CPE) must also be fitted. The software contains a few commands that can be used to control the hopper. It's not recommended to use this serial protocol for applications other than for test purposes. Other more sophisticated protocol like Cctalk should be used for serial communication.

- The HOPPER connector should be connected to the host machine. Refer to Table 1 for a complete pin description.

- JP1 en JP2 are jumpers that define the operation mode of the hopper. Refer to section 2 for the jumper definitions.

- JP3 set the power supply voltage of the board.
 12VDC : short pin 1 and 2.
 24VDC : short pin 2 and 3.

3. Interface signals

Table 1 lists all signals.

Pin	Signal Type	Description
1	High impedance (internal 100K pull up to 5V)	Connected to Hopper Low Level signal plate
2	Low impedance (internal 100 ohm to 0V)	Connected to Hopper Low Level ground plate
3	Opto Coupler LED (Anode) with 4K7 serie resistor	Start input
4	Opto Coupler LED (Anode) with 4K7 serie resistor	Mode input
5	Opto Coupler open collector output	Busy / Ready output
6	Opto Coupler open collector output	Coin Exit output
7	Power supply input	Power Supply (12 or 24VDC)
8	Opto Coupler Input LEDs(-) and output transistors emitter are connected to this pin.	Signal common ground
9	Power supply ground	Power ground (0V)

Table 1: Pin description

3.1. Low Level Pins

Pin 1 and 2 are connected directly to the low level plates of the hopper.

Pin 2 is also internal connected to the power supply ground through a 100 ohm resistor.

Any charge that is build up by the friction of the moving coins is discharged through this resistor.

Pin 2 is also connected to the microcontroller via a buffer. The busy /ready signal (pin 5) is influenced by the status of this low level pin.

3.2. Start input

The start input is connected to the microcontroller via an opto coupler. The signal common (pin 8) is usually connected to the signal ground of the machine controlling the hopper.

The start input must be set to a voltage between 5-24 VDC (input high) in order to activate the start signal.

3.3. Mode input

This input can be used to put the hopper in logic mode (input low) or pulsed mode (input high).

3.4. Busy / Ready output

This open collector output is used to indicate the status of the hopper.

The output is active low if pin 8 (signal common) is 0V.

The Busy / Ready output is set active low if the hopper is busy paying out coins or if the low level plates do not make contact anymore through the coins.

3.5. Coin Exit output

The coin exit output is active low if pin 8 (signal common) is 0V.

The coin-sensor may be a normally open or normally closed type.

In mode 1 and 2, after a coin has left the hopper, a active low pulse of 50ms is transmitted.

In mode 0, the coin exit signal follows the opto-sensor signal of the hopper in such a way, that when a coin passes the opto-interrupter, the coin exit signal will go low.

3.6. VIN

The power supply must be 12 or 24VDC depending on JP3. The power supply must be able to deliver 2.5 amps continuously and 5 amp peaks during 50 ms.

3.7. Signal Gnd

This signal is the common minus(-) input of the opto-coupled inputs and outputs. It is usually connected to the power ground pin (pin 9) of the interface connector.

3.8. Motor control

Connecting and interrupting the +12 or +24VDC supply controls the motor. The motor is automatically stopped when the power-supply is switched off. Motor duty cycle is 2:1.

An electronic overload detection system protects the motor and in case of a coin jam it will temporarily turn the hopper disc several times in the opposite direction until the jam is solved if not the motor switches itself off.

3.9. Current consumption

With maximum coin load: 850mA average.

Current is zero whilst stopped (hopper disconnected).

Motor start-up and reversing surge: 2A falling to approx. 850mA (hopper full) or 400mA (hopper empty) after 200ms.

3.10. Power supply requirements

- 12VDC and 24VDC nominal ($\pm 10\%$)
- maximum ripple voltage $\pm 2.4V$
- absolute maximum voltage: 26.4VDC
- minimal voltage when using 24VDC connection: 18VDC
- minimal voltage when using 12VDC connection: 10.8VDC
- switch / reverse current: 2A

3.11. Coin counting

Coin counting speed is 6 to 7 coins per second. All paid out coins pass by the optical sensor indirectly.

The coin exit output changes from high impedance to low impedance status.

This output stays high as long as the hopper is in the "Off" status (power disconnected).

When a coin appears at the counter pawl under the exit bridge the PCB controls the coin verification and releases a logic signal. The opto-coupler and the counter pawl detect paid-out coins.

Payout signal: open collector NPN - active low, maximum sink of 25mA at 35Volt maximum.

Minimum time obstructs optics 30ms - minimum.

Time between coins: $\pm 100ms$.

4. Hopper Operation

4.1. Mode's

The hopper can be set in one of 3 different operating modes:

1. Continuous mode (JP1 shorted, JP2 shorted)
2. Logic mode (JP1 open, JP2 open)
3. Pulsed mode (JP1 open, JP2 shorted)

These modes are described in the next chapters.

4.2. Continuous mode

The Continuous mode is activated if JP1 is shorted and JP2 is shorted. The power must be put off / on in order for the continuous mode to be activated.

4.3. Continuous mode normal operation

In this mode (JP1 shorted, JP2 shorted), the hopper starts immediately ejecting coins after the power supply (24VDC) is present on pin 7 of the interface connector.

The hopper stops as soon as the power is gone.

In this mode, the Coin Exit signal output on pin 6 of the interface connector follows any level changes of the coin-sensor of the hopper. The Coin Exit signal will always be active low however. This is done in order to be compatible with existing hopper control boards, and gives the machine total control over the hopper.

When the power is removed just before a coin is being ejected from the hopper, the coin may not leave the hopper properly and will be stuck in the coin sensor of the hopper.

It is important to remove the power only after the coin has left the hopper entirely. See Figure 2.

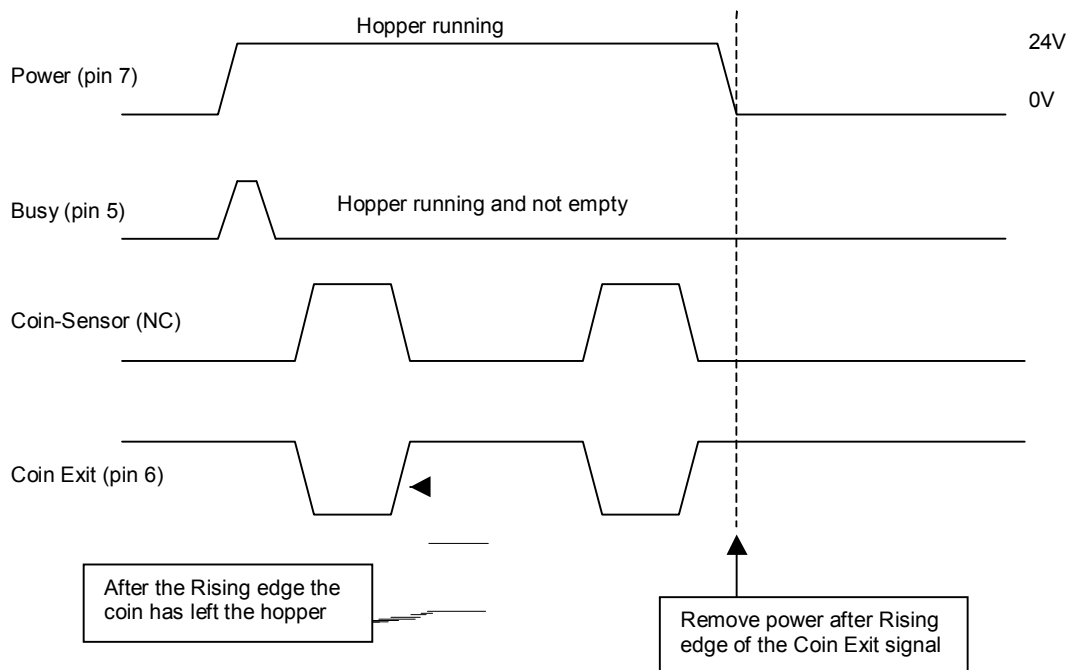

Figure 2: Timing in Continuous mode

4.4. Continuous mode anti-jam operation

If the hopper for some reason blocks (jams) the motor current will rise fast. When the current exceeds a certain trip level (around 1.6 Amp), the motor will be reversed for T_clear ms. This is done to withdraw any coins from the coin exit port that may have caused the block.

After the first reverse period the hopper is started again. If the hopper still blocks, the motor will be reversed again for T_jamrev ms, and then started again. This procedure is repeated until the hopper starts ejecting coins again. If the jam is not cleared, the motor will stop due to its thermal fuse protection.

See timing figure below.

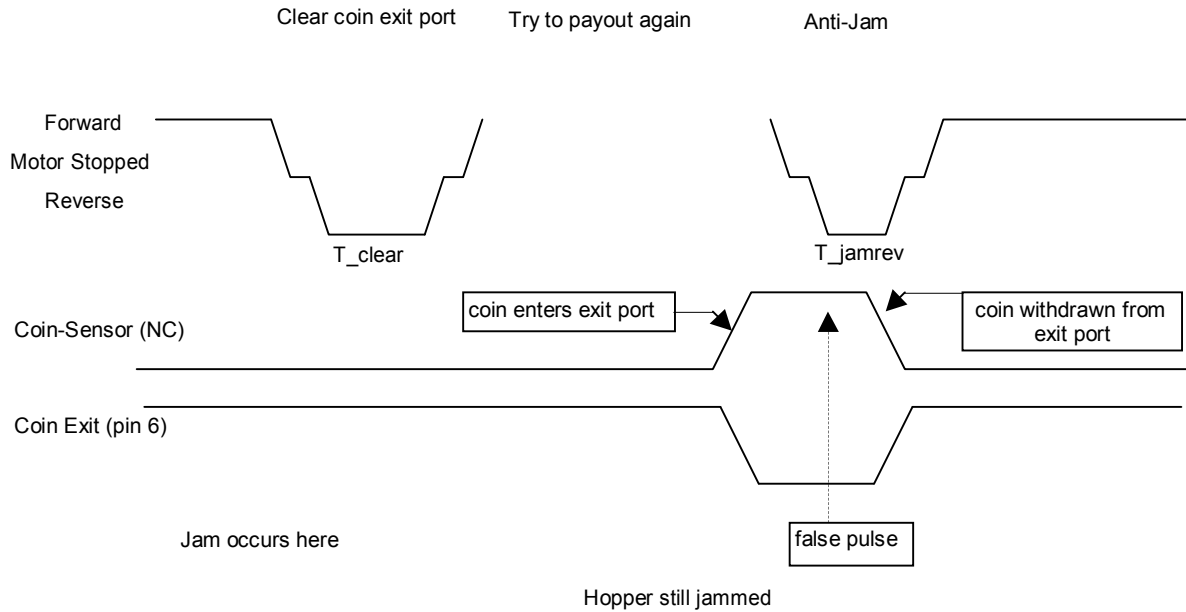

Figure 3: Anti-Jam timing in continuous mode

4.5. Logic mode

The Logic mode is activated if JP1 and JP2 are open. The power must be put off / on in order for the logic mode to be activated.

4.6. Logic mode normal operation

In this mode, the hopper is started by setting the start level to a voltage between 5 - 24V. The hopper is stopped if the start level changes again to 0V. When the hopper is started in the logic mode, the software inside the microcontroller of the hopper board will check the level of the coin-sensor first, which can be a normally open (NO) or normally closed (NC) type. The software needs this information in order to determine if a coin has left the hopper during payout. Then the motor is started forward, and coins will be ejected. After a coin has fully left the hopper, the software transmits an active low pulse of T_{exit} ms on the Coin Exit signal of the interface connector. See figure below.

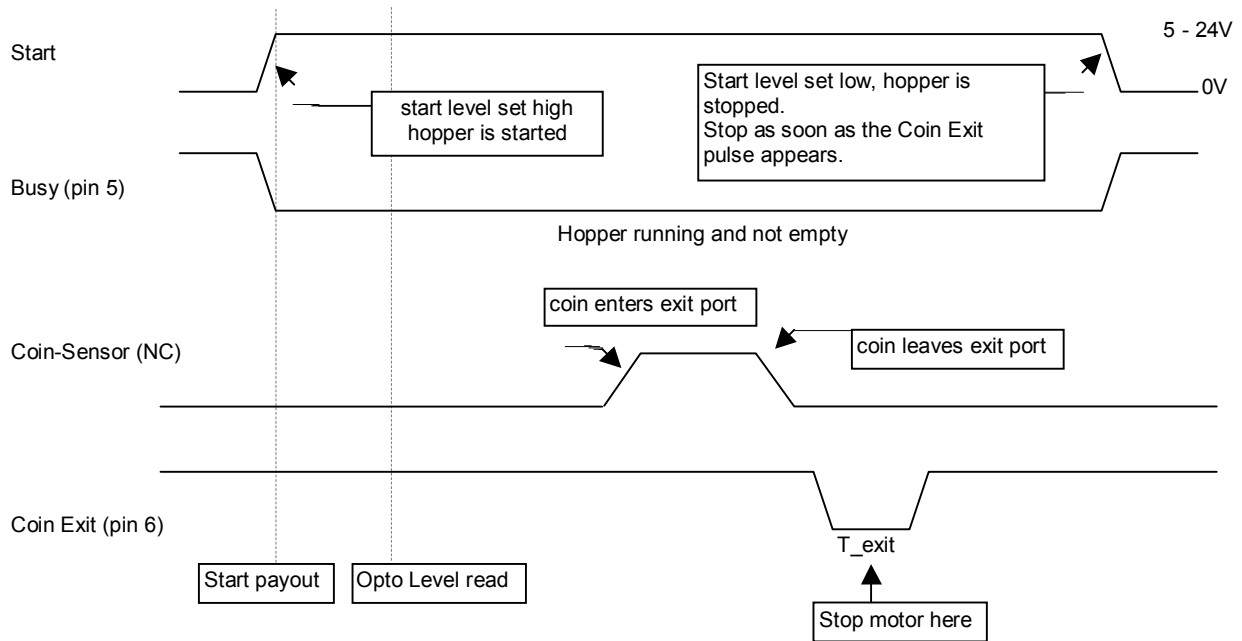

Figure 4: Hopper payout timing

The Busy signal (pin 5) will be low as long as the hopper is running. It will also be low if the low level plates do not make contact anymore. The hopper is empty then. When the Busy signal is high, the hopper is ready to accept another payout.

4.7. Logic mode anti-jam operation

If the hopper for some reason blocks (jams) the motor current will rise fast. When the current exceeds a certain trip level (around 1.6 Amp), the motor will be reversed for T_clear ms. This is done to withdraw any coins from the coin exit port that may have caused the block. After the first reverse period the hopper is started again. If the hopper still blocks the motor will be reversed for T_jamrev ms, and started again. This procedure is repeated until the hopper starts ejecting coins again. If the jam is not cleared, the motor will stop due to its thermal fuse protection. Any coin-sensor level changes during the anti-jamming procedure are discarded. See timing figure below.

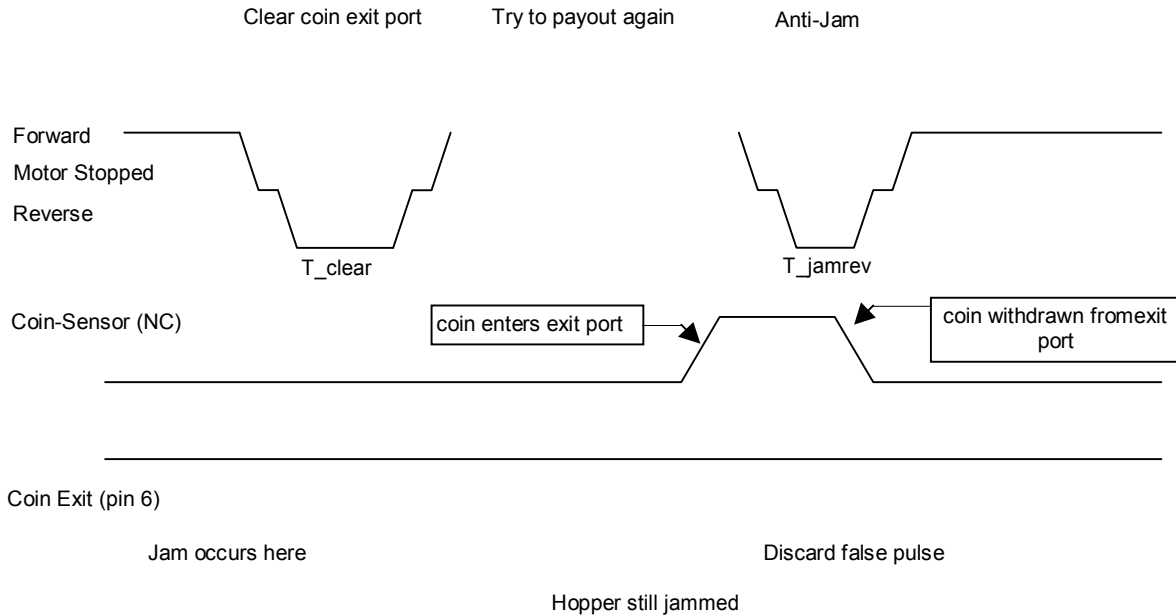

Figure 5: Anti-Jam timing in logic mode

4.8. Pulsed mode

The Pulsed mode is activated if JP1 is open and JP2 is shorted. The power must be put off / on in order for the pulsed mode to be activated.

4.9. Pulsed mode normal operation

In this mode, for each active high or active low pulse on the start input, the hopper ejects a coin. When the hopper is started in the pulsed mode, the software inside the microcontroller of the hopper board will check the level of the coin-sensor first, which can be a normally open (NO) or normally closed (NC) type. The software needs this information in order to determine if a coin has left the hopper during payout. Then the motor is started forward, and coins will be ejected. After a coin has fully left the hopper, the software transmits an active low pulse of T_{exit} ms on the Coin Exit signal of the interface connector. See figure below.

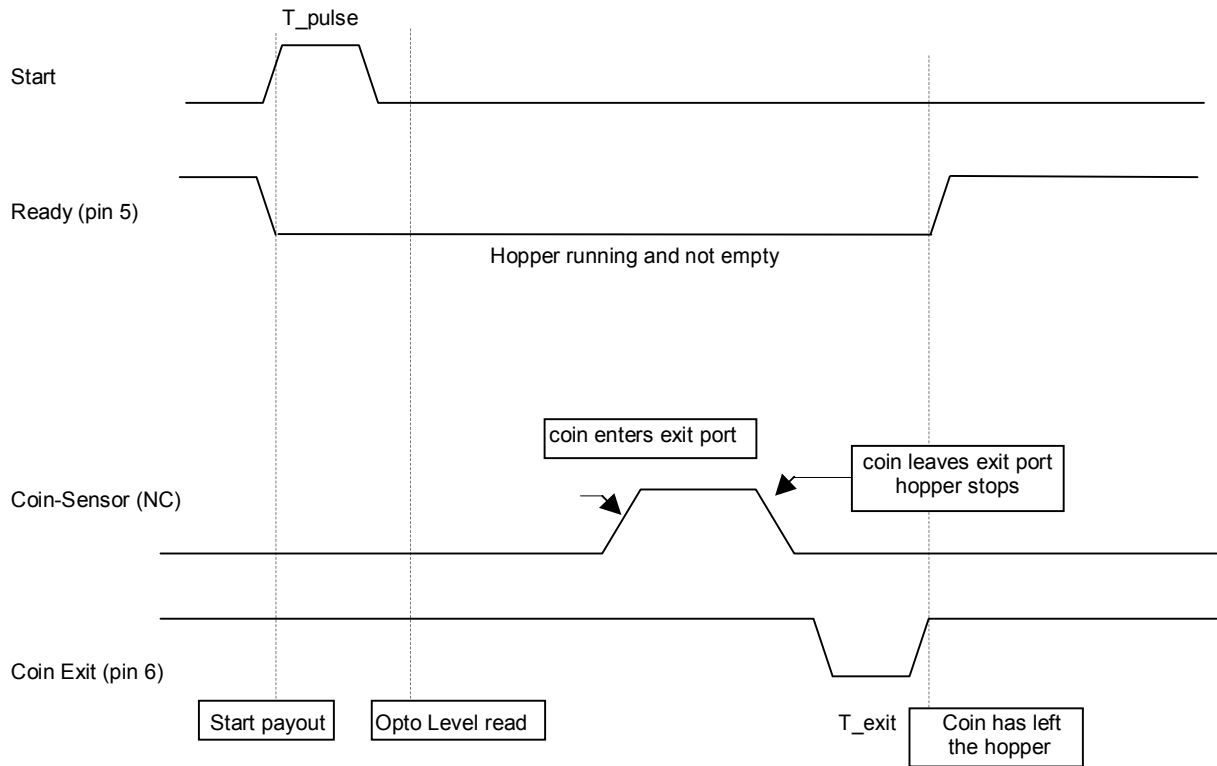

Figure 6: Pulsed mode timing

4.10. Pulsed mode anti-jam operation

Refer to section 3.2.2 for a description of the anti-jam operation.

5. Mechanical features

5.1. Dimensions & Weight

Dimensions:

D: 125mm

W: 125mm

H: 152mm

Weight:

780 grams

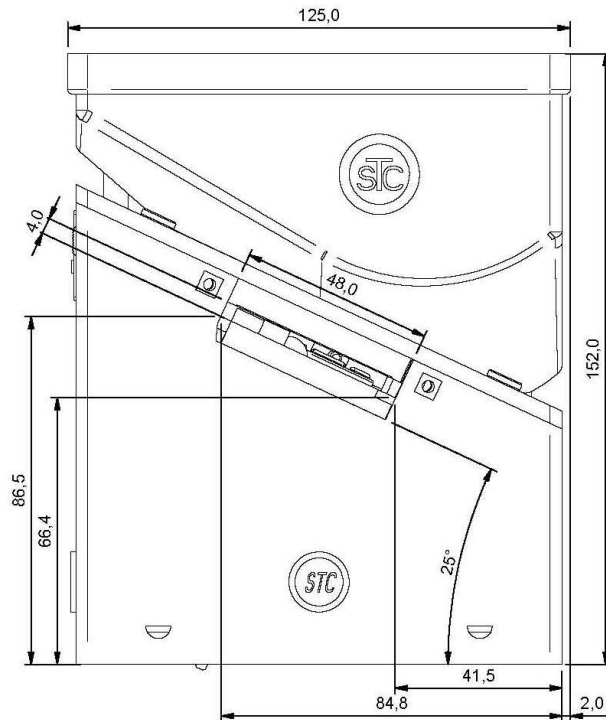

5.2. Removing the Motor and Gearbox

The motor is controlled by the PCB and operates the disc by means of gears and shafts.

The gearbox is constructed according to the sun and planet system.

The motor can easily be exchanged by first unplugging the connector from the PCB and then dismantling the motor holder which is connected to the gear box by means of a bayonet catch.

Press down the engraved slide on the motor housing and turn the motor housing in an anti-clockwise direction to take it off.

Now take a new motor and refit into the motor holder.

The gearbox can also be removed completely by unscrewing the three screws, which attach the gearbox to the platform and removing the rolling-pin on top of the motor shaft.

The Counter Pawl fits an Opto output detector with a transmitter inside the Hopper. The Counter Pawl makes sure that the coin always leaves the Hopper and the construction is done in such a way that once the coin leaves the disc it can never return to the Hopper.

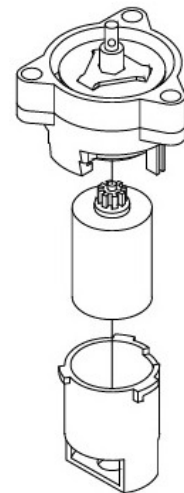

5.3. Coin routing

The coins enter the hopper via the top of the Coin Cup and are ejected sideways via de Coin Exit.

8. Optional add-ons

8.1. Cup extension (Part No. 10-0200)

A 65mm high extension together with standard coin-cup increases the capacity of the cup from 300 to 500 coins of €2.00 (25.75mm in diameter, 2.2mm thick). It can be used with all coins with diameters up to 31mm.

A second extension is possible for coins with a maximum diameter of 25.75mm. This increases the capacity to 700 coins of €2.00.

Hopper dimensions - with one extension:
 D: 122mm W: 122mm H: 218mm
 Hopper dimensions - with two extensions:
 D: 122mm W: 122mm H: 284mm

Weight
 860 grams
 940 grams

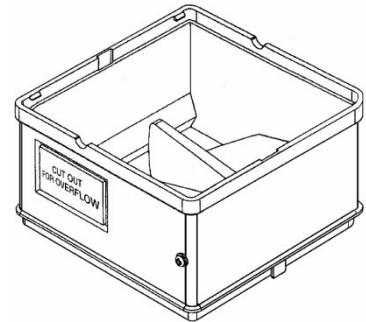

8.2. Cube Hopper spillage cover (Part No. 10-0005)

Designed to prevent coin spillage.

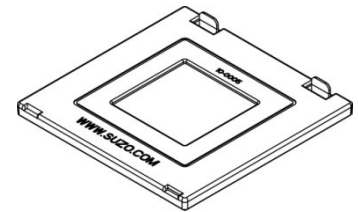

TECHNICAL SPECIFICATIONS

Nominal Operating Voltage	12VDC \pm 10% or 24VDC -25% +10%
Minimal Operating Voltage	10.8VDC by 12V or 18V DC by 24V
Storage temperature	- 20°C to + 70°C.
Operating temperature	- 0°C to + 50°C.
Humidity	Min. 20% - Max. 75%
Motor Duty Cycle	2:1
Payout speed	6 to 7 coins per second
Payout position	4 sides
Max. current not loaded	400mA
Max. current loaded	850mA
Max. current	2A (when jamming)
Machine Connector	9-way connector, Part No. 22-01-2095 + Pins, Part No. 08-50-0032
Payout signal	Open collector-active low 25mA-35V
Coin Diameter size	15.40mm – 31.00mm
Coin Thickness size	1.3mm - 3.2mm
Min. time between coins	100ms
Min. time obstructs optics	30ms
MCBF	500.000
Maintainable life	>3 millions
Maintainable disk	750.000 – 1.000.000

Design and specifications are subject to change without notice.
Wijzigingen in ontwerp en technische gegevens voorbehouden, zonder kennisgeving.
La conception et les spécifications sont modifiables sans préavis.
El diseño y especificaciones están sujetos a cambios sin previo aviso.

This manual is intended only to assist the reader in the use of this product and therefore International shall not be held liable for any loss or damage whatsoever arising from the use of any information or particulars in, or any omission from this manual or any incorrect use of the product.

WARNING!

Failure to observe the interface requirements specified in this technical manual may result in miscounts, damage to the electronics and the motor of the hopper or create unacceptable voltage drops, affecting other units depending on the same power supply.

