

NV200 User Manual

GA794-A

Innovative Technology

Secure Banknote Handling Solutions Of The Future



This is a draft version of the manual. Features and specification may change.

Revision History

INNOVATIVE TECHNOLOGY LTD			
Title:	NV200 USER MANUAL		
Drawing No	Author	Date	Format
GA794	RJS	21/04/08	MS Word 2000
Issue	Release Date	Modified By	Comments
A	21/04/08	RJS	First Draft

Contents

1	Introduction	4
2	Specification	5
3	General Description	6
4	Ordering Information	7
5	Installation	8
5.1	Mounting.....	8
5.2	Lock installation.....	8
6	Machine and User Interfaces	11
6.1	16-way external connector.....	11
6.2	USB connection.....	11
6.3	Dip Switches.....	12
6.4	Bezel LED's.....	12
6.4.1	Operational Colour.....	12
6.4.2	Diagnostic Codes.....	12
6.5	Modes of Operation.....	13
6.5.1	Smiley® Secure Protocol (SSP).....	13
6.5.2	Parallel.....	14
6.5.3	Binary.....	15
6.5.4	Pulse.....	16
6.5.5	MDB (Multi Drop Bus).....	17
6.5.6	ccTalk®.....	18
6.5.7	Other interfaces	18
7	Re-Calibration	19
8	Reprogramming the NV200	20
8.1	Dataflash® Memory Cards.....	20
8.2	Validator Manager Software.....	21
8.3	Validator Programming System (DA3).....	21
9	Cash Box Removal	22
10	Note Path Access.....	22
11	Bezel Installation.....	23
12	Validator Head Unit Removal.....	23
	Appendix A – Dimensions	24
	Appendix B – Escrow Function.....	26
	Appendix C – Implemented ccTalk® commands	27
	Appendix D – Parts List and Exploded Drawings.....	28

This is a draft version of the manual. Features and specification may change.

1 Introduction

This manual describes the operation of the NV200 Bank Note Validator, programmed with Firmware Version 4.02 or greater, and is intended for those who will install the NV200 equipment

A.u.S. Spielgeräte GmbH
Scheydgasse 48
A-1210 Wien

Tel: +43 1-271 66 00
Fax: +43 1-271 66 00 75
E-mail: verkauf@aus.at
Web site: <http://www.aus.at>

WARNING

ONLY SUITABLY TRAINED PERSONNEL SHOULD CARRY OUT ANY WORK ON THIS EQUIPMENT IN ACCORDANCE WITH ALL CURRENT LOCAL, NATIONAL AND INTERNATIONAL HEALTH AND SAFETY REGULATIONS.

Smiley® and the ITL Logo are international registered trademarks and they are the property of Innovative Technology Limited.

Innovative Technology has a number of European and International Patents and Patents Pending protecting this product. If you require further details please contact the factory.

Innovative Technology, Automated transactions or bellis technology are not responsible for any loss, harm, or damage caused by the installation and use of this product. This does not affect your local statutory rights. If in doubt please contact Innovative Technology for details of any changes

CAUTIONS:

NEVER EXCEED THE RECOMMENDED ENVIRONMENTAL AND ELECTRICAL LIMITS.

DO NOT ATTEMPT TO LUBRICATE THE MECHANISMS AS THIS MAY AFFECT THE NOTE TRANSPORT.

DO NOT POLISH THE LENS AS THIS MAY ALTER THE OPTICAL CHARACTERISTICS.

IF THE NV200 VALIDATOR IS DISASSEMBLED THE UNIT MUST BE RE-CALIBRATED AND RE INITIALISED, FOLLOWING RE-ASSEMBLY.

Innovative Technology Ltd has a policy of continual product improvement. As a result the products supplied may vary from the specification described here.

This is a draft version of the manual. Features and specification may change.

2 Specification

Electrical Supply	Minimum	Maximum
Supply Voltage (V DC) Absolute Limits	+11V	+13.5V
Supply Ripple Voltage	0	0.25V @100 Hz
Supply Currents:		
Standby		0.4A
Validating		1.5A
Peak (Motor Stall)		3.0A

Table 1 - Electrical Supply Specification

Environment	Minimum	Maximum
Temperature	+3°C	+50°C
Humidity	5%	95% Non condensing

Table 2 - Environmental Specification

Interface Logic levels	Logic Low	Logic High
Inputs	0V To +0.5V	+3.7 V +12V
Outputs with 2K2Ω pull up	0.6V	Pull up voltage of host interface
Maximum Current Sink	50mA per output	

Table 3 - Interface Logic Levels

Note sizes accepted	Width: 60 – 85mm, Length: 115 – 167mm
Weight	2.8Kg
Note to note time	3 Seconds
Escrow	Single note
Cash box capacity	500 street grade notes
Interface	SSP, Parallel, Pulse, Binary, ccTalk, MDB. (Contact ITL for other interface availability)

Table 4 - General Specification

3 General Description

The NV200 is the next generation of note reader from Innovative Technology Ltd.

- Simple, quick re-programming (approximately 30 seconds) with 128 bit encrypted memory card, PIN number protected
- Up to 16 channels (Depending on mode of operation)
- Secure dual lock cash box with 500 used note capacity
- Seamless note path
- Can accept notes up to 85mm wide and 167mm long
- 3 seconds note to note
- Reads industry standard barcodes in any direction
- Note centring and straightening mechanism
- Single note escrow function
- User definable colour for bezel illumination



Figure 1 - The NV200

This is a draft version of the manual. Features and specification may change.

4 Ordering Information

When ordering NV200 the following information must be specified:

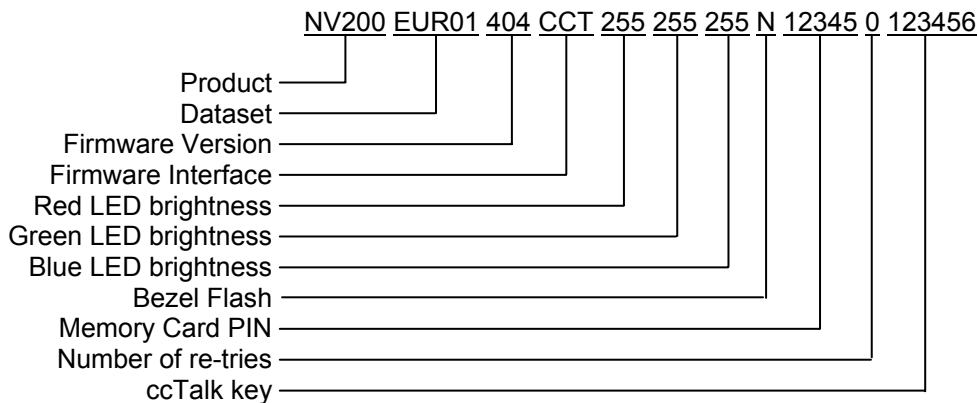

Figure 2 - Order Code Example

Dataset – This code signifies the currency and notes included, for example, EUR01 contains 5, 10, and 20 Euro notes, EUR02 contains the 5, 10, 20 and 50 Euro notes. For available datasets and dataset codes, please refer to the currency download section of our website www.aus.at

Firmware – This code is the version of firmware required. If left blank, the latest current version will be programmed

Interface – This is the 3 letter code of the required communications interface. For more details of available interfaces, see chapter 6.5 - Modes of Operation.

- SSP – Smiley Secure Protocol
- MDB – Multi-Drop-Bus
- PL1 – Pulse Mode
- CCT – ccTalk
- PAR – Parallel
- BIN – Binary

LED Brightness – The values of brightness for each colour of the bezel LED's in the order Red, Green, Blue between 0 and 255. If no colour is specified, the NV200 will be shipped with the bezel colour set to magenta by default.

Bezel Flash – Y/N. If the bezel flash is set to Y, when enabled, the validator bezel will flash at a rate of 1Hz. If set to N, the bezel will be illuminated constantly when the validator is enabled.

Memory Card PIN – The required PIN number for the memory card. Programming with a memory card has the added security of setting a PIN number. The PIN programmed into the memory card must match the PIN programmed into the NV200 for re-programming to take place.

Number of Re-tries – The number of times the NV200 will read the note should it not be recognised on the first attempt. This value must be between 0 and 2

ccTalk Encryption Key – The required ccTalk encryption key if the selected interface is CCT. If left blank, a key of 123456 will be used.

5 Installation

5.1 Mounting

The NV200 can be mounted via the mounting holes on either side of the chassis using 4 x M4 fixing screws and a suitable mounting bracket. See Appendix A – Dimensions for the location of the mounting holes.

NOTE:

- **The length of the screw must be no more than 6mm plus the thickness of the mounting bracket.**

It is also possible to mount the NV200 via fixing holes in the rear of the chassis. Care must be taken not to obstruct the cash box when using the rear fixing holes.

5.2 Lock installation

The NV200 has the provision of fitting three locks for extra security. One lock can be added to the front of the NV200 that locks the validator head and cash box into position without the need of external brackets. Another two locks can be added to the cash box itself for extra security. If the locks are fitted to the cashbox, when it is removed from the validator, it is not possible to gain access to the notes contained without first unlocking both locks.

The cams required for the lock are supplied with the NV200 attached to the back of the lock blanking plugs. For lock fitting instructions, see drawing numbers GA605 and GA606 on the following pages.

Suggested lock:

This is a draft version of the manual. Features and specification may change.

Insert Drawing Number GA605

This is a draft version of the manual. Features and specification may change.

Insert Drawing Number GA606

6 Machine and User Interfaces

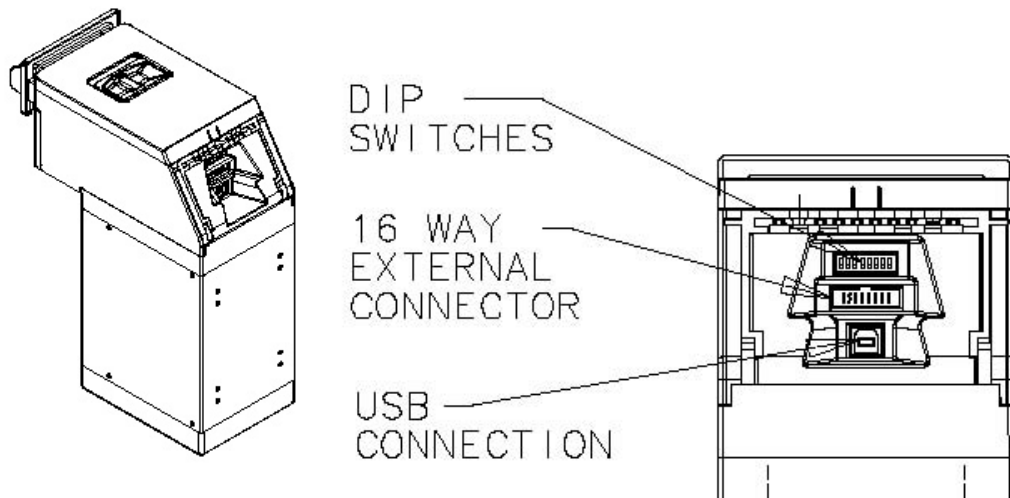

Figure 3 - Connector And Switch Location

6.1 16-way external connector

The function of pins 1-8 changes according to which machine interface is being used. See the individual interface descriptions for details.

Pin	Name	Type	Description
1	Vend 1	Output	Open collector outputs. Function changes depending on machine interface protocol (see individual interface descriptions for details)
2	Vend 2	Output	
3	Vend 3	Output	
4	Vend 4	Output	
5	Inhibit 1	Input	Inputs are held high to internal +5V via 10KΩ. Function changes depending on machine interface protocol (see individual interface descriptions for details)
6	Inhibit 2	Input	
7	Inhibit 3	Input	
8	Inhibit 4	Input	
9	Busy	Output	Active LOW when the NV200 is transporting, reading or stacking a note
10	Escrow	Input	Enable the escrow function by holding LOW in Parallel, Pulse or Binary modes (See Appendix B – Escrow Function)
11	-	-	Not connected
12	-	-	Not connected
13	Factory Use Only		Do Not Connect
14	Factory Use Only		Do Not Connect
15	+Vin	Power	Nominal 12V DC supply
16	0V	Ground	0V supply

Table 5 - 16-way External Connector Pin Out

6.2 USB connection

The USB connector can be used to program the NV200 with the validator manager software, and for communications when used in SSP and SIO modes. When used for programming only, no external power supply is required.

If notes are to be inserted, power must be applied to the NV200 via the 16-pin external connector before connecting the USB cable.

This is a draft version of the manual. Features and specification may change.

6.3 Dip Switches

The bank of 8 dip switches have the following function:

Switch No	Function	Switch OFF (↓)	Switch ON (↑)
1	Disable Barcode	Barcode read enabled	Barcode read disabled
2	Channel 1 Inhibit	Channel 1 enabled	Channel 1 disabled
3	Channel 2 Inhibit	Channel 2 enabled	Channel 2 disabled
4	Channel 3 Inhibit	Channel 3 enabled	Channel 3 disabled
5	Channel 4 Inhibit	Channel 4 enabled	Channel 4 disabled
6	Channel 5 Inhibit	Channel 5 enabled	Channel 5 disabled
7	Channel 6 Inhibit	Channel 6 enabled	Channel 6 disabled
8	Programming Mode	Switch from OFF to ON and back to OFF to activate	

Table 6 - Dip Switch Functions

6.4 Bezel LED's

6.4.1 Operational Colour

The operational colour of the bezel illumination can be set to a user definable colour by using the BNV Currency Manager Software. Each of the three colours of LED in the bezel can be set to a different brightness level (0-255) to achieve the desired colour. The colour is selected using the sliders in the set validator options section of the BNV Currency Manager Software. The default colour for the bezel is Magenta

Examples:



Red – 200, Green – 125, Blue – 255



Red – 255, Green – 255, Blue – 0

The Bezel LED's can also be set to either solid or flashing at a rate of once per second when the note validator is enabled.

Re-programming the NV200 with a memory card that has been programmed using the NV Card Utilities software will also set the colour and operation of the LED's.

6.4.2 Diagnostic Codes

If the NV200 detects an error that is preventing normal operation, the Bezel LED's will indicate the cause of the problem by flashing in a certain sequence as shown in Table 7 - Bezel LED Diagnostic Codes. The LED's will first flash red a number of times (at 300ms intervals) to indicate the general area of the problem, then flash blue a number of times (at 120ms intervals) to give a more exact cause. The full sequence repeats after a pause of 700ms.

Number of RED flashes	Number of BLUE flashes			
	1	2	3	4
1	Note Path Open	Note Path Jam	Unit Not Initialised	
2	Cash Box removed	Cash Box Jam		
3	Firmware Checksum	Interface checksum	EEPROM Checksum	Dataset Checksum
4	PSU too Low	PSU too High	Card Not Formatted	

Table 7 - Bezel LED Diagnostic Codes

This is a draft version of the manual. Features and specification may change.

6.5 Modes of Operation

6.5.1 Smiley® Secure Protocol (SSP)

SSP is a secure serial interface specifically designed to address the problems experienced by cash handling systems in gaming machines. Problems such as acceptor swapping, reprogramming acceptors and line tapping are all addressed. This interface is recommended for all new designs.

The interface uses a master slave model, the host machine is the master and the peripherals (note acceptor, coin acceptor or coin hopper) are the slaves.

Data transfer is over a multi-drop bus using clock asynchronous serial transmission with simple open collector drivers. The integrity of data transfers is ensured through the use of 16 bit CRC checksums on all packets.

SSP mode can be activated temporarily for the purpose of re-programming the NV200. This is done by switching DIPSwitch 8 ON then OFF again.

NOTE: This mode can only be cancelled by re-programming via the Validator Manager program or a DA3. Please ensure you are aware of all the NV200 programmed settings before entering this mode. Failure to restore the original setting will stop the NV200 from operating in the host machine

Connections:

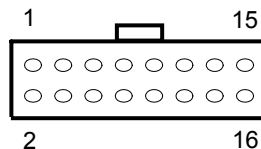

Pin	Name	Type	Description
1	Vend 1	Output	Serial Data Out (Tx)
2	Vend 2	Output	Not Used
3	Vend 3	Output	Not Used
4	Vend 4	Output	Not Used
5	Inhibit 1	Input	Serial Data In (Rx)
6	Inhibit 2	Input	Not Used
7	Inhibit 3	Input	Not Used
8	Inhibit 4	Input	Not Used
9	Busy	Output	Not Used
10	Escrow	Input	Not Used
11	-	-	Not connected
12	-	-	Not connected
13	Factory Use Only		Do Not Connect
14	Factory Use Only		Do Not Connect
15	+Vin	Power	Nominal 12V DC supply
16	0V	Ground	0V supply

Table 8 - SSP Pin Description

Other Information:

Minimum time between polls: - 200ms

Default SSP address: - 0x00

For detailed information and full protocol specification please refer to SSP Interface Specification ITL (Drawing GA138), this is available from the ITL website www.aus.at

To help in the software implementation of the SSP, ITL can provide DLL controls and Visual Basic applications on request. Please contact technik@aus.at for more information.

This is a draft version of the manual. Features and specification may change.

6.5.2 Parallel

In parallel mode the NV200 will issue a 100ms ($\pm 3\%$) active LOW pulse on the relevant vend line. A maximum of 4 channels can be used.

Connections:

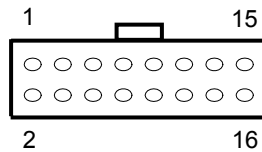

Pin	Name	Type	Description
1	Vend 1	Output	Channel 1 credit, 100ms ($\pm 3\%$) active LOW pulse.
2	Vend 2	Output	Channel 2 credit, 100ms ($\pm 3\%$) active LOW pulse.
3	Vend 3	Output	Channel 3 credit, 100ms ($\pm 3\%$) active LOW pulse.
4	Vend 4	Output	Channel 4 credit, 100ms ($\pm 3\%$) active LOW pulse.
5	Inhibit 1	Input	Inhibit channel 1 by holding this pin HIGH, hold LOW to enable.
6	Inhibit 2	Input	Inhibit channel 2 by holding this pin HIGH, hold LOW to enable.
7	Inhibit 3	Input	Inhibit channel 3 by holding this pin HIGH, hold LOW to enable.
8	Inhibit 4	Input	Inhibit channel 4 by holding this pin HIGH, hold LOW to enable.
9	Busy	Output	Active LOW when the NV200 is transporting, reading or stacking a note
10	Escrow	Input	Enable the escrow function by holding LOW (See Appendix B – Escrow Function)
11	-	-	Not connected
12	-	-	Not connected
13	Factory Use Only		Do Not Connect
14	Factory Use Only		Do Not Connect
15	+Vin	Power	Nominal 12V DC supply
16	0V	Ground	0V supply

Table 9 - Parallel and Binary Pin Description

Vend signals: (pins 1 to 4) The four channels have their own individual outputs. If a note is recognised then the relevant Vend line is set low for a period of 100ms $\pm 3\%$. Pulses outside these limits should be rejected as a precaution against false triggering.

Inhibit inputs: (Pins 5 – 8) Channels 1 to 4 have their own inhibit input to allow the host machine to refuse specified notes. To inhibit a channel, the relevant inhibit input must be held high. To enable a channel, the corresponding inhibit must be latched low so that notes may be accepted.

If all four inhibits are high simultaneously then the NV200 will be disabled. In this state the bezel will not illuminate and if a note is inserted the motor will run in reverse preventing the insertion of the note.

All four inhibits may be connected together to create a 'global' inhibit. In this way the NV200 may be brought in and out of operation by the host machine.

Busy Output: (Pin 9). This is a general-purpose busy signal. It is active low while the NV200 is in operation.

Escrow Control: (Pin 10) Hold this pin Low to enable the single note escrow function. (See Appendix B – Escrow Function).

This is a draft version of the manual. Features and specification may change.

6.5.3 Binary

In Binary mode, the NV200 will issue a binary pattern on vend lines 1 to 4 as shown in Table 10 - Binary Credit Outputs. A maximum of 15 channels can be used.

Vend 1	Vend 2	Vend 3	Vend 4	Credit Channel
LOW	HIGH	HIGH	HIGH	Channel 1
HIGH	LOW	HIGH	HIGH	Channel 2
LOW	LOW	HIGH	HIGH	Channel 3
HIGH	HIGH	LOW	HIGH	Channel 4
LOW	HIGH	LOW	HIGH	Channel 5
HIGH	LOW	LOW	HIGH	Channel 6
LOW	LOW	LOW	HIGH	Channel 7
HIGH	HIGH	HIGH	LOW	Channel 8
LOW	HIGH	HIGH	LOW	Channel 9
HIGH	LOW	HIGH	LOW	Channel 10
LOW	LOW	HIGH	LOW	Channel 11
HIGH	HIGH	LOW	LOW	Channel 12
LOW	HIGH	LOW	LOW	Channel 13
HIGH	LOW	LOW	LOW	Channel 14
LOW	LOW	LOW	LOW	Channel 15

Table 10 - Binary Credit Outputs

Connections:

Connections in Binary mode are the same as for Parallel mode.

Note: Channels higher than four cannot be individually inhibited, but will be globally inhibited if inhibits 1 to 4 are held high.

This is a draft version of the manual. Features and specification may change.

6.5.4 Pulse

In Pulse mode the NV200 outputs a number of pulses on Vend 1. The number of pulses for each channel is different and set to default values within the dataset. The number of pulses and the pulse duration can be modified using the Validator Manager Software. A maximum of 16 channels can be used.

Connections:

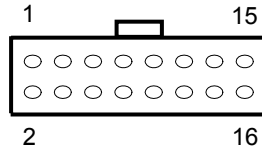

Pin	Name	Type	Description
1	Vend 1	Output	Credit pulse stream output.
2	Vend 2	Output	Not Used
3	Vend 3	Output	Not Used
4	Vend 4	Output	Not Used
5	Inhibit 1	Input	Inhibit channel 1 by holding this pin HIGH, hold LOW to enable.
6	Inhibit 2	Input	Inhibit channel 2 by holding this pin HIGH, hold LOW to enable.
7	Inhibit 3	Input	Inhibit channel 3 by holding this pin HIGH, hold LOW to enable.
8	Inhibit 4	Input	Inhibit channel 4 by holding this pin HIGH, hold LOW to enable.
9	Busy	Output	Active LOW when the NV200 is transporting, reading or stacking a note
10	Escrow	Input	Not Used
11	-	-	Not connected
12	-	-	Not connected
13	Factory Use Only		Do Not Connect
14	Factory Use Only		Do Not Connect
15	+Vin	Power	Nominal 12V DC supply
16	0V	Ground	0V supply

Table 11 - Pulse Mode Pin Description

Note: Channels higher than four cannot be individually inhibited, but will be globally inhibited if inhibits 1 to 4 are held high.

This is a draft version of the manual. Features and specification may change.

6.5.5 MDB (Multi Drop Bus)

MDB is a serial bus interface commonly used in electrically controlled vending machines. This is a 9600 Baud Master-Slave system where the NV200 banknote validator is a slave to a master controller. A Vending Machine Controller (VMC) has the capability of communicating with 32 peripherals or slaves.

Connections:

To use the NV200 in MDB mode, an IF5 external interface is required. The IF5 regulates the power supply and opto-isolates the communication lines.

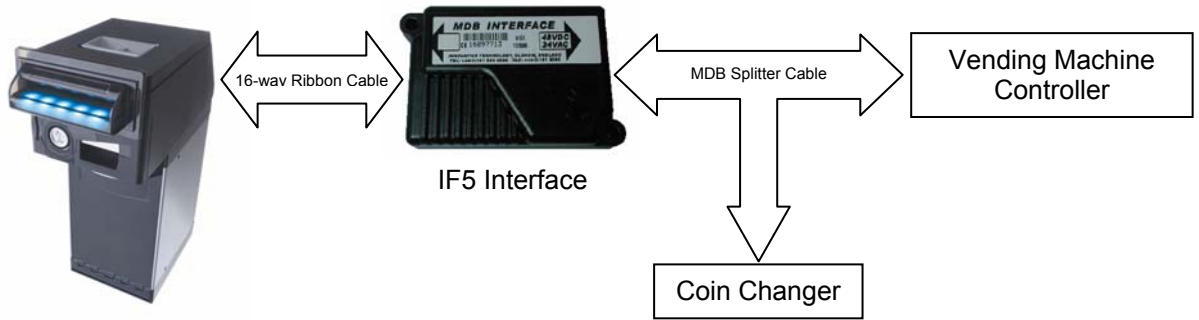

Figure 4 - Connecting the NV200 in MDB mode

Other Information:

MDB address: - 0x30

NV200 supports the MDB Protocol Version 1, Level 1.

For detailed information and full protocol specification, please refer to www.vending.org

This is a draft version of the manual. Features and specification may change.

6.5.6 ccTalk®

ccTalk® is a serial communication protocol commonly used in gaming machines. The protocol allows various types of cash handling equipment to be connected to the same 3-wire bus (+12V, 0V and Data). To use the NV200 in ccTalk mode, pins 1 and 5 (Tx and Rx) must be connected together as the data line.

Connections:

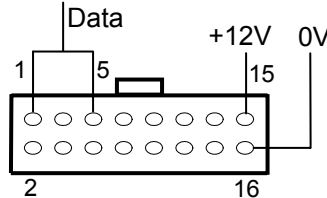

Pin	Name	Type	Description
1	Vend 1	Output	Serial Data. Must also be connected to pin 5
2	Vend 2	Output	Not Used
3	Vend 3	Output	Not Used
4	Vend 4	Output	Not Used
5	Inhibit 1	Input	Serial Data. Must also be connected to pin 1
6	Inhibit 2	Input	Not Used
7	Inhibit 3	Input	Not Used
8	Inhibit 4	Input	Not Used
9	Busy	Output	Not Used
10	Escrow	Input	Not Used
11	-	-	Not connected
12	-	-	Not connected
13	Factory Use Only		Do Not Connect
14	Factory Use Only		Do Not Connect
15	+Vin	Power	Nominal 12V DC supply
16	0V	Ground	0V supply

Table 12 - ccTalk Pin Description

Other Information:

For a list of supported commands please see Appendix C – Implemented ccTalk® commands

For detailed information and full protocol specification, please refer to www.cctalk.org

Default ccTalk address: - 0x28 (40 dec)

Encrypted ccTalk uses 16 bit CRC checksum. If the encryption is disabled, the user can select either simple 8 bit or 16 bit CRC checksums.

6.5.7 Other interfaces

Any queries regarding interfaces not mentioned in this manual should be made to technik@aus.at

7 Maintenance and Re-Calibration

7.1 Routine Maintenance

The NV200 Validator has been designed to minimise any performance variation over time. Much of this is achieved by careful hardware and software design. The protective positioning of the sensor lenses prevents damage and airborne contamination reaching the optical sensors.

However, depending upon the environment the NV200 may at some time require cleaning.

CAUTION: DO NOT USE SOLVENT BASED CLEANERS SUCH AS ALCOHOL, PETROL, METHYLATED SPIRITS, WHITE SPIRIT OR PCB CLEANER. THIS WILL RESULT IN PERMANENT DAMAGE TO THE VALIDATOR, ONLY USE A MILD DETERGENT.

To clean, pull the top cover release latch forward and lift the upper cover. The note path is now exposed for cleaning. Carefully wipe the surfaces with a soft lint free cloth that has been dampened with a water and mild detergent solution (i.e. household washing up liquid). Take particular care around all the sensor lenses, ensuring they are clean and dry.

7.2 Re-calibration

The NV200 has an in-built self-calibration system that maintains the optical sensors at their best operating point. However if the NV200 is disassembled for any reason it will need to be re-calibrated. Re-calibration may only be performed under license from ITL, contact technik@aus.at for further details. Re-calibration can only be performed in conjunction with the diagnostics software option in the ITL BNV Currency Manager Program.

This is a draft version of the manual. Features and specification may change.

8 Reprogramming the NV200

The NV200 can be updated in a number of ways as follows:

- Atmel Dataflash Memory Cards
- ITL Bank Note Validator Currency Manager Software
- Validator Programming System (DA3)

8.1 Dataflash® Memory Cards

The slot at the front of the NV200 can be used to reprogram the validator from an Atmel DataFlash® Memory card, without the need to remove the validator from the host machine. The validator firmware, dataset and optional settings can all be programmed in approximately 30 seconds by simply inserting a programmed memory card into the slot at the front of the validator. If only the dataset is to be reprogrammed this time is reduced to approximately 10 seconds (depending on the number of notes in the dataset) and if only the optional settings are being changed (i.e. the bezel illumination colour), programming is complete in less than one second.

For security reasons, the memory card is protected by 128 bit encryption and an optional 5 digit PIN code. The PIN code programmed onto the card must match the code programmed into the NV200 to enable the programming operation.

The card must first be programmed using a DA3 and the NV Card Utilities software following the steps below clicking 'next' after each step (See document number GA796 – NV Card Utilities for more information).

- Run the NV Card utilities software and insert the dataflash card into the DA3 memory card slot A
- Select the required firmware/dataset file
- Modify the dataset pulse settings, channel allocations etc as required
- Select required firmware interface
- Set desired operational bezel colour, illumination mode (steady or flashing) and the number of retries
- Set the 5 digit PIN number (if required)
- Update card

Once the memory card has been programmed with the required information, the NV200 is re-programmed by simply inserting the card into the memory card slot. During re-programming the Bezel LED will flash, alternating from BLUE and MAGENTA, and change to solid GREEN when the programming is complete. If there is an error, the Bezel LED's will change RED instead of GREEN.

NOTE:

Only Atmel 8MB DataFlash® cards can be used. Standard SD memory cards will not function.

This is a draft version of the manual. Features and specification may change.

8.2 Validator Manager Software

The ITL BNV Currency Manager software offers the following functions:

- Program the Validator by downloading pre-prepared download file which contains the the latest currency and firmware.
- Change the colour of the front bezel LED's
- Check the version of firmware and currency already loaded on a NV200 unit.
- Adjust the channel and pulse configuration on a pre-programmed NV200 to your own requirements.
- Use diagnostic functions to check Validators operation

The NV200 can be connected directly via the USB port, or with either a DA1 or DA2 kit connected to the 16-way external connector.

When connected to a computer, the NV200 must be set to SSP mode. SSP programming mode is activated temporarily for the purpose of re-programming the NV200. This is done by switching DIPSwitch 8 ON then OFF again.

NOTES:

- **The Validator must be set to SSP Mode when connected to a computer and then returned to the original settings when complete.**
- **This mode can only be cancelled by re-programming via the Validator Manager program or a DA3. Please ensure you are aware of all the NV200 programmed settings before entering this mode. Failure to restore the original setting will stop the NV200 from operating in the host machine**
- **ITL BNV Currency Manager 3.2.2 or higher must be used to access the NV200 functions**

8.3 Validator Programming System (DA3)

The DA3 is a programming system designed to enable the programming of ITL Bank Note Validators in the field without the use of a PC.

Once the DA3 has been programmed the user can:

- Update the existing software within a validator to the latest versions using the BNV Match Download function.
- Reprogram the validator to accept a different currency using the BNV Override Download function
- Test the functionality of the validator away from the Host machine.

For full DA3 operation and functionality details please refer to the DA3 User Manual (Document number GA339)

NOTE:

- **The Validator must be set to SSP Mode when programming with a DA3 and then returned to the original settings when complete.**
- **This mode can only be cancelled by re-programming via the Validator Manager program or a DA3. Please ensure you are aware of all the NV200 programmed settings before entering this mode. Failure to restore the original setting will stop the NV200 from operating in the host machine**

This is a draft version of the manual. Features and specification may change.

9 Cash Box Removal

To remove the cash box from the NV200, first unlock the 'Cashbox & Head Release Lock' (if fitted). Pull the silver 'Cashbox Release Handle'. The cashbox will slide forward for removal.

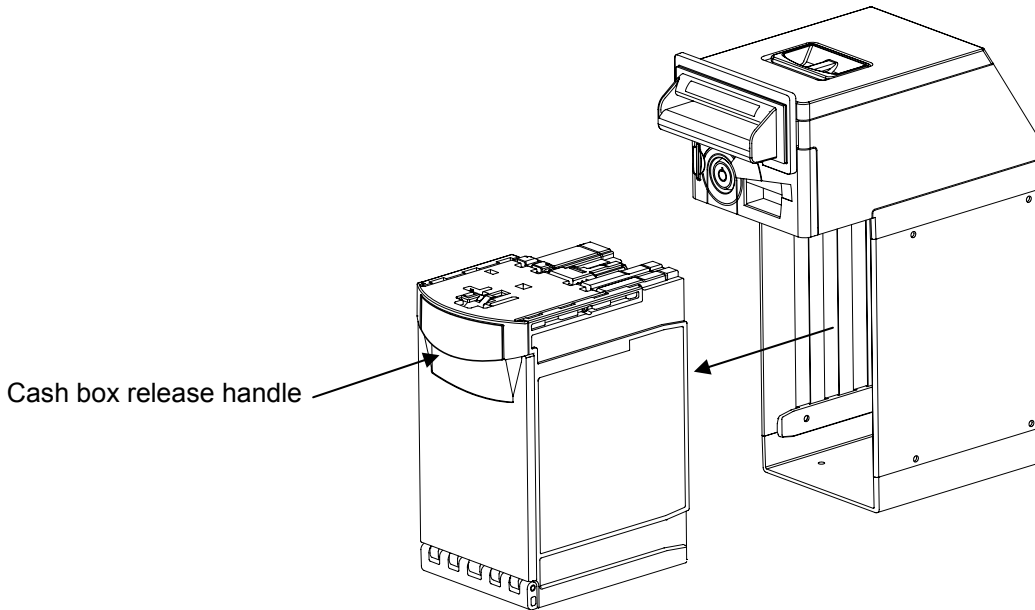

Figure 5 - Cashbox Removal

To replace the cashbox, simply slide it into the chassis and push until it clips into place.

10 Note Path Access

To access the note path of the NV200, pull the top cover release latch forward and lift the upper cover.

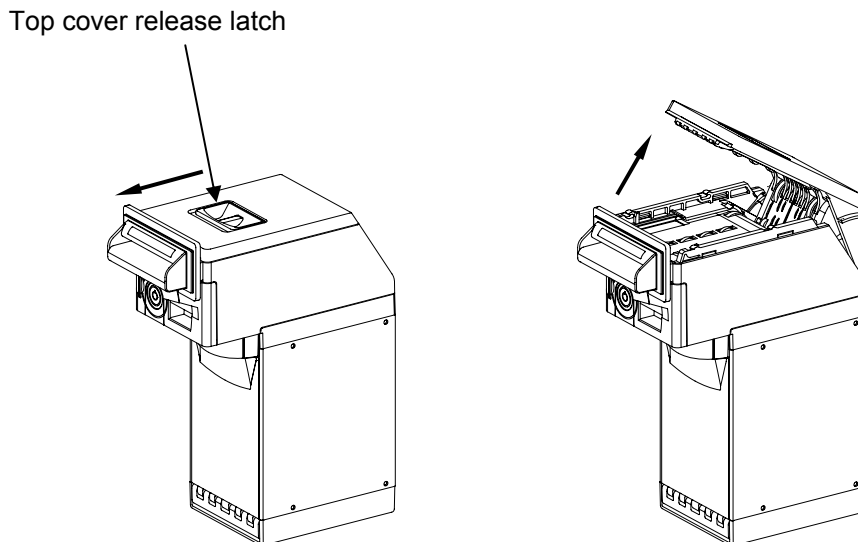

Figure 6 - Note Path Access

To close the note path, simply push the cover down until it clicks into place.

This is a draft version of the manual. Features and specification may change.

11 Bezel Installation

To fit the bezel to the NV200 access to the note path is required. Lift the upper cover by pulling the latch forward. Connect the cable from the bezel assembly to the socket located on the front of the validator head unit and click the assembly down into place. Close the note path upper cover. M3 screws can be fitted to hold the bezel assembly securely in place if required.

12 Validator Head Unit Removal

To remove the head unit from the validator, first unlock the 'Cashbox & Head Release Lock' (if fitted). Lift the silver 'Head Release Latch' located on the front of the validator, slide the head unit forward and lift up away from the chassis.

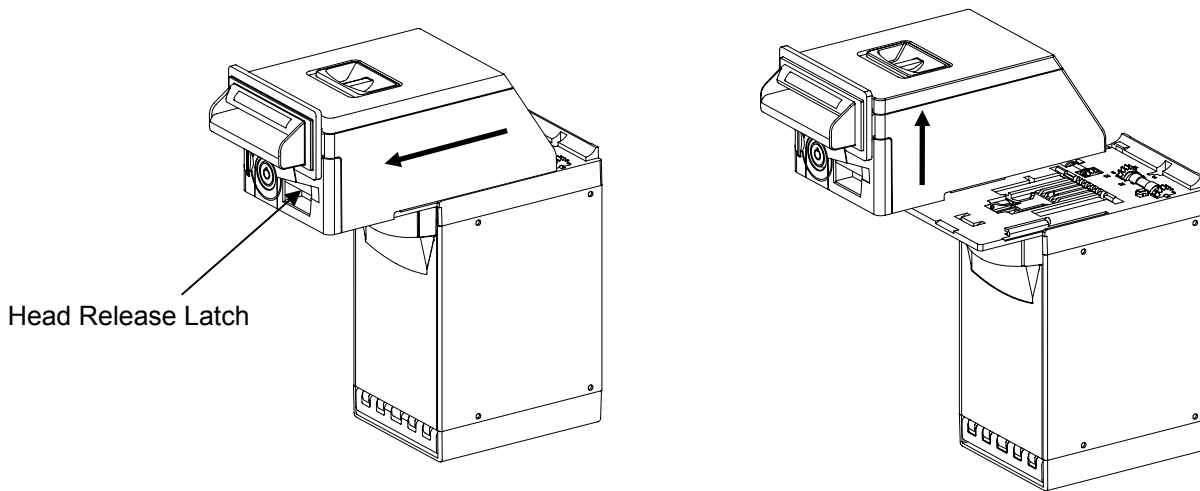

Figure 7 - Validator Head Removal

To replace the head unit, align the lugs on the chassis with the groove on the underside of the head assembly and slide the head assembly backwards until it clicks securely into place.

This is a draft version of the manual. Features and specification may change.

Appendix A – Dimensions

Drawing number GA604 on the following page shows the external dimensions of the NV200 with mounting hole locations.

This is a draft version of the manual. Features and specification may change.

Insert Drawing number GA604

This is a draft version of the manual. Features and specification may change.

Appendix B – Escrow Function

The NV200 has a single note escrow facility (pin 10) used in Parallel and Binary modes. This allows the Validator to hold onto the note once accepted, and then only stack the note in the cash box when the host machine confirms that the Vend operation has been completed. If no confirmation of the Vend is received then the note will be returned to the customer after 30 seconds, (see Figure 8 - Escrow Timing Diagram).

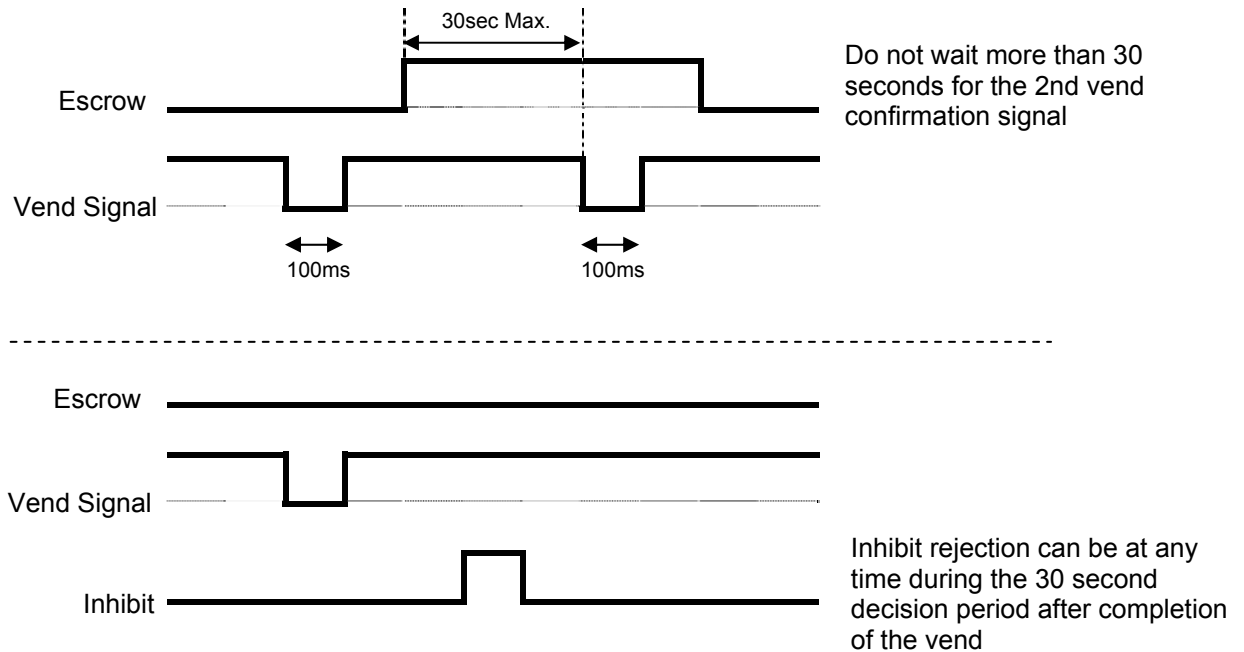

Figure 8 - Escrow Timing Diagram

If the host machine itself aborts the transaction by setting the corresponding inhibit input high, the note is returned immediately.

The sequence of operations is as follows:

- Pin 10 held low awaiting note insertion.
- Note inserted. Validator issues a 100ms pulse on the appropriate channel.
- The host machine initiates vend process.
- The host machine sets pin 10 high to indicate that it wants the note. If this is not done within 30 seconds the Validator will return the note.
- The Validator issues a 100ms pulse on the appropriate channel after pin 10 going high to indicate final acceptance of the note.

NOTE: If the signal has not been received within 30 seconds it indicates the customer has forcibly retrieved the note and the vend must be aborted.
- The vend process is completed.
- The host machine sets pin 10 low in expectation of the next vend.

The host machine can force the return of the note to the customer by setting the inhibit line high, at any time before the end of the 30 second time-out. For channels above 4, setting all the inhibits high will cause a note reject.

In the event of a note being forcibly removed from the mouth of the NV200 during the 30-second interval, the NV200 will go out of service for 45 seconds.

Appendix C – Implemented ccTalk® commands

Command	Header
SIMPLE_POLL	254
ADDRESS_POLL	253
ADDRESS_CLASH	252
ADDRESS_CHANGE	251
ADDRESS_RANDOM	250
REQUEST_POLLING_PRIORITY	249
REQUEST_MANF_ID	246
REQUEST_EQUIP_CAT_ID	245
REQUEST_PRODUCT_CODE	244
SERIAL_NUMBER	242
REQUEST_SOFTWARE_REVISION	241
READ_OPTO_STATES	236
PERFORM_SELF_CHECK	232
SET_INHIBITS	231
REQ_INHIBITS	230
SET_MASTER_INHIBIT	228
REQ_MASTER_INHIBIT	227
REQUEST_INS_COUNT	226
REQUEST_ACCEPT_COUNT	225
REQUEST_DATA_STORAGE_AVAIL	216
REQUEST_OPTION_FLAGS	213
CALCULATE_ROM_CHECKSUM	197
REQUEST_BUILD_CODE	192
REQUEST_BASE_YEAR	170
REQUEST_ADDRESS_MODE	169
READ_BUFFERED_BILL_EV	159
REQUEST_BILL_ID	157
REQUEST_COUNTRY_SCALING	156
REQUEST_BILL_POSITION	155
ROUTE_BILL	154
MODIFY_BILL_OPERATING_MODE	153
REQUEST_BILL_OPERATING_MODE	152
STACKER_CYCLE	147
OPERATE_BI_MOTORS	146
REQUEST_CURRENCY_REVISION	145
SWITCH_ENCRYPTION_CODE	137
STORE_ENCRYPTION_CODE	136
REQUEST_COMMS_REVISION	4
RESET_DEVICE	1

Table 13 - Implemented ccTalk commands

This is a draft version of the manual. Features and specification may change.

Appendix D – Parts List and Exploded Drawings

The Following Assemblies are available as spares

Part Number	Description	Where Used
PA610	Bezel assy	PA631
PA621	Validator final assy	PA631
PA629	Cashbox final assy	PA631
PA630	Chassis assy	PA631
PM614	Lock Cam Gear	-
MC247	Cashbox Lock Cam	-

This is a draft version of the manual. Features and specification may change.

Insert Drawing Number PA631